

PIUSI

*Fluid Handling
Innovation*

BY-PASS 3000

PIUSI SUPREME

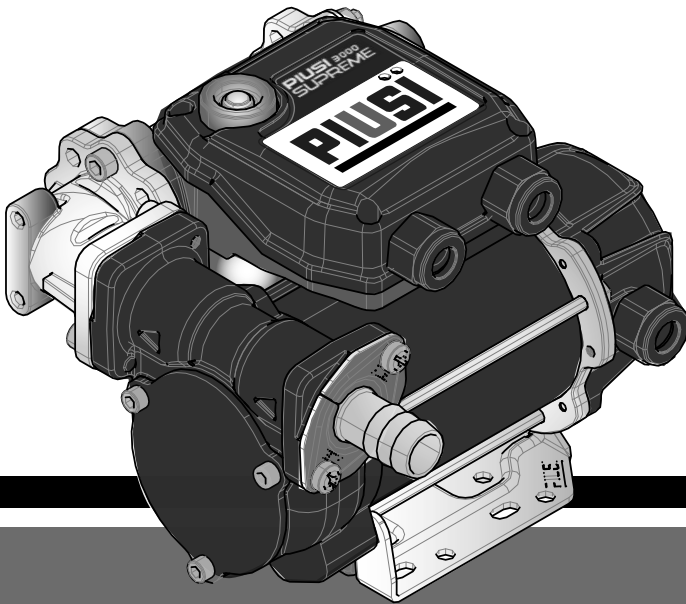

**MADE
IN
ITALY**

Manuale di Installazione, uso e manutenzione
Installation, use and maintenance manual

IT
EN

BULLETIN MO709 ITEN_02

ENGLISH

Bulletin M0709

CONTENTS

1	GENERAL PRECAUTIONS	40
1.1	SYMBOLS USED IN THE MANUAL	40
1.2	MANUAL STORAGE.....	40
1.3	RIGHTS FOR REPRODUCTION	40
1.4	EU DECLARATION OF CONFORMITY	41
1.4.1	FACSIMILE OF THE EU DECLARATION OF CONFORMITY	41
2	INSTRUCTIONS AND SAFETY NORMS.....	42
3	TRANSPORT, HANDLING AND STORAGE.....	45
3.1	DIMENSIONS AND WEIGHTS	45
3.2	STORAGE.....	46
3.2.5	AMBIENT CONDITIONS.....	46
4	MACHINE AND MANUFACTURER IDENTIFICATION.....	46
4.1	PLATES POSITIONS.....	47
5	DESCRIPTION OF MAIN PARTS.....	48
5.1	ELECTRIC PUMP STRUCTURE AND MAIN PARTS.....	48
5.1.1	Pump unit and electric motor	48
6	TECHNICAL CHARACTERISTICS	50
6.1	PERFORMANCE.....	51
7	USE	52
7.1	INTENDED USE	52
7.1.1	Fluids allowed	52
7.1.2	Prohibited fluids and relative hazards	53
7.2	IMPROPER USE.....	53
8	INSTALLATION	54
8.1	PRELIMINARY CHECKS	54
8.2	PUMP POSITIONING.....	54
8.3	CONSIDERATIONS CONCERNING THE DELIVERY AND SUCTION LINES.....	55
8.3.1	Delivery.....	55
8.3.2	Suction	55
8.3.3	Accessories.....	56
8.4	ELECTRICAL CONNECTIONS.....	56
9	FIRST START-UP AND DAILY USE.....	58
9.1	FIRST START-UP.....	58
9.2	FIRST PRIMING	60
9.3	DAILY USE	60





10 MAINTENANCE	63
10.1 ROUTINE MAINTENANCE.....	63
10.2 EXTRAORDINARY MAINTENANCE.....	63
11 TROUBLESHOOTING	64
11.1 LED SIGNALS AND TROUBLESHOOTING	64
11.2 MECHANICAL AND HYDRAULIC PROBLEMS	65
12 SCRAPPING AND DISPOSAL	67
13 REPLACEMENT PARTS TABLE	68

1 GENERAL PRECAUTIONS

In order to protect workers' safety and to avoid the risk of any damage, before performing any operation, please read and become familiar with the contents of the instruction manual.

1.1 SYMBOLS USED IN THE MANUAL

In order to signal particularly important instructions or warnings, the following symbols are used:

	<p>ELECTRICAL HAZARD This symbol identifies the risk of electric shock from equipment powered by voltages potentially dangerous for humans.</p>
	<p>CAUTION This symbol indicates accident prevention regulations addressed to operators and/or other people concerned.</p>
	<p>WARNING This symbol indicates that there is a possibility of damaging the units and/or their components.</p>
	<p>NOTE This symbol indicates useful information.</p>
	<p>Read the instruction manual carefully.</p>

1.2 MANUAL STORAGE

This manual must be intact and completely readable. The final users, as well as the qualified technicians authorised to installation and maintenance must be able to view it at any time.

1.3 RIGHTS FOR REPRODUCTION

THIS MANUAL BELONGS TO PIUSI S.p.A.

All rights for reproduction are reserved for PIUSI S.p.A.

The text cannot be used in other printed documents unless expressly authorised in written form by PIUSI S.p.A. © PIUSI S.p.A. **WHOLE OR PARTIAL REPRODUCTION OF THIS MANUAL IS FORBIDDEN.**

PIUSI S.p.A. is the exclusive owner of all rights envisaged by applicable laws, including the rules concerning copyrights. All the rights deriving from such norms belong to PIUSI S.p.A.

Reproduction, publication, editing, transcription, public disclosure, distribution, sale in any form, translation and/or processing, loan, and any other activity concerning this manual, also partial, are reserved by law to PIUSI S.p.A.

1.4 EU DECLARATION OF CONFORMITY

1.4.1 FACSIMILE OF THE EU DECLARATION OF CONFORMITY

The undersigned: PIUSI S.p.A
Via Pacinotti 16/A z.i. Rangavino
46029 Suzzara - Mantua - Italy

DECLARES on its own responsibility, that the equipment described below:

Description: Pump designed to dispense diesel
Model: By-pass 3000 SUPREME
Serial number: see the Lot Number on the plate affixed to the product
Year of construction: See the production year on the plate stamped on the product.







Complies with the following legislation:





- **Machine Regulations**
- **Electromagnetic compatibility**
- **Electrical and electronic equipment**
- **Radio equipment**



The technical file is at the disposal of the competent authorities in response to a motivated request made to PIUSI S.p.A. or upon receipt of a request sent to the following email address: doc_tec@piusi.com.

THE ORIGINAL DECLARATION OF CONFORMITY IS SUPPLIED SEPARATELY IN CONJUNCTION WITH THE PRODUCT

2 INSTRUCTIONS AND SAFETY NORMS

	<p>FIRE HAZARD If there are flammable liquids in the working area, flammable vapours may be present and may cause fire or explosion during use.</p>
	<p>EXPLOSION HAZARDS To eliminate fire and explosion hazards use the equipment only in well ventilated places. Keep work area free of debris, including rags and spilled or open containers of solvent and gasoline. Do not plug or unplug power cords or turn lights on or off when flammable fumes are present. Keep a working fire extinguisher in the work area.</p>
	<p>RISK OF FIRE AND EXPLOSION This product is NOT SUITABLE for installation and use in Classified Areas subject to the presence of potentially explosive atmospheres. PIUSI 3000 SUPREME has not been designed to comply with the ATEX directive or to operate in potentially explosive atmospheres or for dispensing flammable liquids with a flash point of < 55°C / 131°F (e.g. petrol).</p>
	
	<p>To avoid static electricity build-up, the metal parts of this equipment must have a protective earth connection. Improper installation or use of the equipment may result in danger of electric shock. All electrical equipment in the work area must have a protective earth connection. Stop operation immediately if static sparking occurs or if you feel a shock. Do not use the dispenser until you have identified and rectified the issue.</p>
	<p>You must avoid any contact between the electrical power supply and the fluid to be pumped Install the equipment in a sheltered location. Do not switch on the fluid dispensing equipment with damaged electrical parts, such as cables, or damaged hydraulic parts, such as the suction/delivery pipe or the delivery nozzle. Call the maintenance technicians immediately and replace all damaged parts before using the equipment.</p>
	<p>NO SMOKING Do not smoke near the fuel transfer pump and do not use the pump near naked flames.</p>

PRECAUTIONS FOR USE	
	PERSONAL PROTECTION EQUIPMENT FEATURES Wear personal protection equipment that is: - suitable to the operations to be performed; - resistant to the various cleaning products used.
PERSONAL PROTECTIVE EQUIPMENT TO BE WORN	
	Safety shoes
	Protective gloves
	Safety glasses

OTHER SAFETY DEVICES	
	<p>INSTRUCTION MANUAL</p> <ul style="list-style-type: none"> - Do not operate the unit when fatigued or under the influence of drugs or alcohol. - Do not leave the work area while equipment is energised or in operation. - Turn off the equipment when not in use. - Do not alter or modify the equipment. Alterations or modifications may void agency approvals and create safety hazards. - Route hoses and cables away from traffic areas, sharp edges, moving parts, and hot surfaces. - Do not twist the hose or use a stronger hose. - Keep children and animals away from the working area. - Respect all safety norms in force. - Do not exceed the maximum working pressure or temperature of the component with the lowest system rating. - See the technical specifications in all machine manuals. - Use liquids and solvents that are compatible with the wet parts of the unit. See the technical specifications in all machine manuals. Read the manufacturer's warnings for liquids and solvents. To obtain more information about the material, request the Safety Data Sheet (MSDS) from your MC distributor or dealer. - Check the unit every day. Repair or replace worn or damaged parts immediately with original manufacturer's spare parts only. - Make sure that the unit is classified and approved in accordance with the regulations for the environment in which it is used. - Use only the unit for its intended purpose. Contact your Dealer for more information.
	<p>TOXIC FLUID OR FUMES HAZARD</p> <p>For issues arising from the treated product with eyes, skin, inhalation and ingestion refer to the safety data sheet of the fluid used Store hazardous fluid in approved containers, and dispose of it according to applicable guidelines. Prolonged contact with the product may cause skin irritation; during delivery phases, always wear protective gloves.</p>
	<p>EQUIPMENT MISUSE</p> <p>Do not use the equipment for uses other than those for which it is designed and built. All different uses may be hazardous for property, animals, or persons.</p>

3 TRANSPORT, HANDLING AND STORAGE

FOREWORD

Given the reduced weight and size of the pumps, they can be handled without the need for any lifting gear. The pumps are carefully packed before shipping. Upon receipt, check the packaging and store in a dry place.

3.1 DIMENSIONS AND WEIGHTS

MODEL	OVERALL WEIGHT (Kg)	PACKAGING DIMENSIONS (mm)
PIUSI SUPREME	Max 8 kg	230 x 160 x H160 300 x 300 x H170 400 x 400 x H200

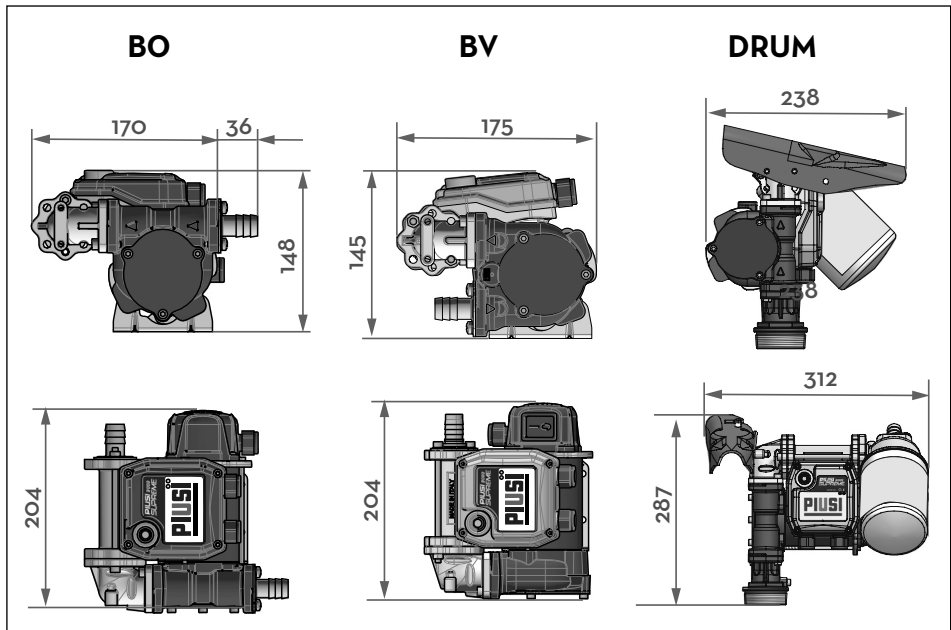

3.2 STORAGE

- Store in a dry, covered place.
- Keep the unit away from dirt and vibrations.

3.2.2 AMBIENT CONDITIONS

TYPE	PIUSI SUPREME
Storage humidity:	Max 90%
Storage temperature:	Min -20 °C Max +60 °C

4 MACHINE AND MANUFACTURER IDENTIFICATION

The PIUSI SUPREME stations are equipped with an identification plate attached to the frame:

- Model.
- Serial number / year of manufacture.
- Technical data.
- CE marking.
- Manual code.





CAUTION: before installing, always make sure the type of dispensing system is correct and suitable for the available power supply (Voltage/Frequency).

4.1 PLATES POSITIONS

The dispensing system is equipped with adhesive decals containing key information for the operator. Make sure the decals do not deteriorate or become detached from the equipment over time.

 **NOTE:** should this occur, please contact customer service and request replacements for any damaged or missing decals, then affix the new decals in their designated positions.

Decals are as follows:

	<p>CE plate with technical data:</p>
	<p>Corner label plate applied on the box</p>

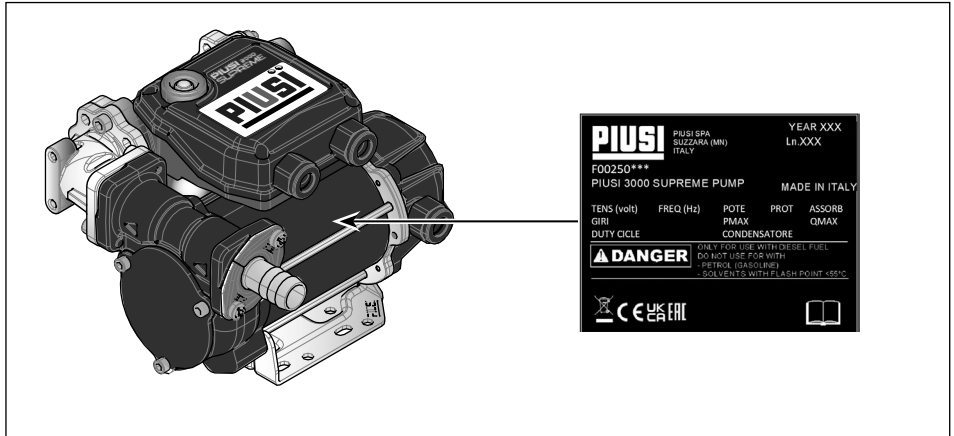

5 DESCRIPTION OF MAIN PARTS

5.1 ELECTRIC PUMP STRUCTURE AND MAIN PARTS

The PIUSI 3000 SUPREME, together with the BP3000 specifications, integrates dispensing management functions, in particular:

5.1.1 Pump unit and electric motor

Made up of a BP3000 12/24V pump and an electronic controller.

PUMP

Self-priming rotary vane volumetric pump, equipped with by-pass valve.

MOTOR

Enclosed brush motor powered by low voltage direct current with protection rating IP55 according to CEI-EN 60034-5, directly flanged to the pump casing.

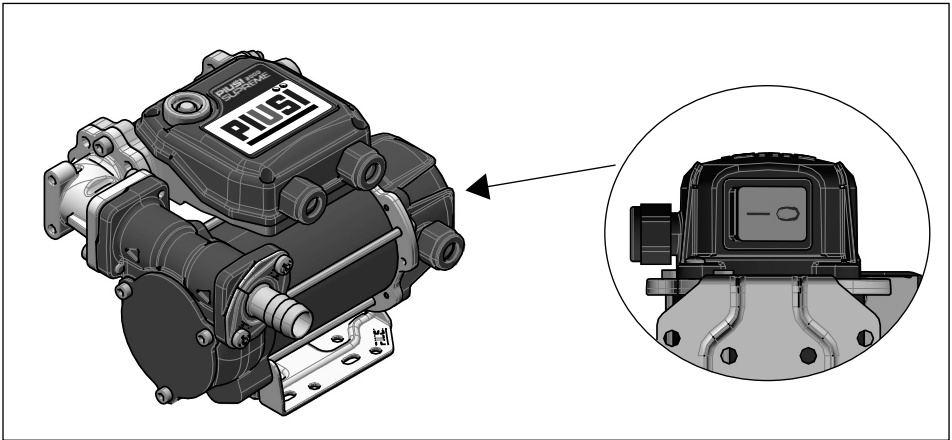

ELECTRONIC CONTROLLER

For managing dispensing operations, controlling operator access via Bluetooth interface (BLE 4.0 and later versions) or i-Button key. It allows users to monitor pump status by means of the interface LEDs on the top cover.

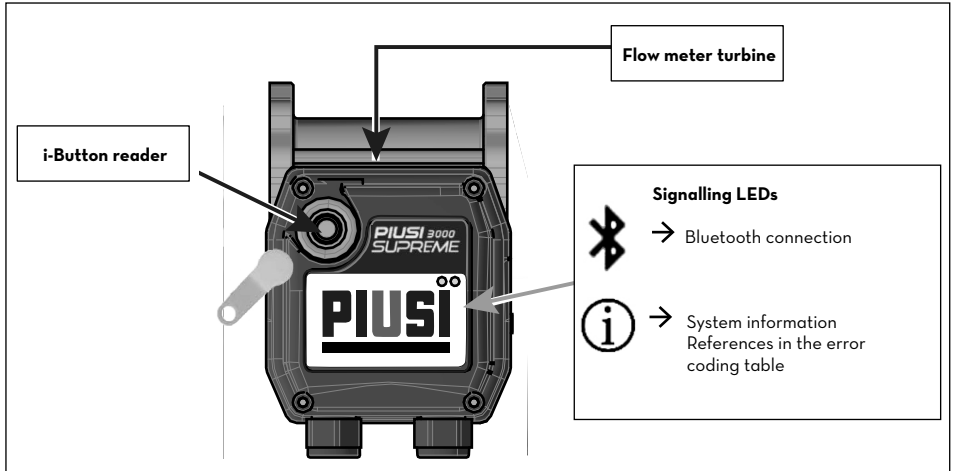

 NOTE: for more detailed information on the PIUSI SUPREME Smartphone connection and communication methods, see the manual for the PIUSI 3000 SUPREME system management App, which can be consulted directly via the App.

 NOTE: there are different types of configurations for the PIUSI 3000 SUPREME product which allow you to enable new functions or expand the number of usable operators. More details on configurations are available in the App manual.

6 TECHNICAL CHARACTERISTICS

Signal	Standard conditions	Limits	Note
Power supply input	12V 24V DC	1. Min voltage 10V 2. Max voltage 30V	The minimum voltage is understood to be measured at the probes during pump operation at maximum load (delivery closed)
Motor voltage	12V	Rated current = 15 A	
Electronic Key Interface	YELLOW key (i-Button); Enabling input from PIUSI electronic key		Operator keys are registered on the PIUSI SUPREME App by means of a manual procedure. It is possible to configure the presence or not of said key.
Fuses	F1 (VDC power supply input) 25A (delayed)		
IP Protection Rating	IP 55		
Working temperature	From -20° C to +50°C		
Storage temperature	From -20° C to +60°C		
Relative humidity	< 90%		
Memory storage	The Electronic Controller can store: - Up to 500 operators - Up to 500 dispensing cycles		The number of operators depends on the Add-On package purchased
Maximum pressure	1.2 bar		
Noise level	<74dB(A)		
Maximum fluid temperature (Diesel)	50 °C		
Maximum fluid Viscosity (Diesel)	11cSt		
Weight (with cable)	Max 8 kg		

6.1 PERFORMANCE

The performance diagram shows the expected flow rate based on back pressure.

Operating point	Flow rate	Voltage	Absorption	4 meters of 3/4" hose	K33 flow meter	Manuale nozzle	Automatic nozzle
A - (Maximum flow rate)	50 l/min	12 V	15 A	●		●	
		24 V	8 A				
B - (High flow rate)	48 l/min	12 V	16 A	●	●	●	
		24 V	8,5 A				
C - (Rated conditions)	46 l/min	12 V	17 A	●	●		●
		24 V	9 A				
D - (By-pass)	O	12	21	Delivery closed			
		24	12				

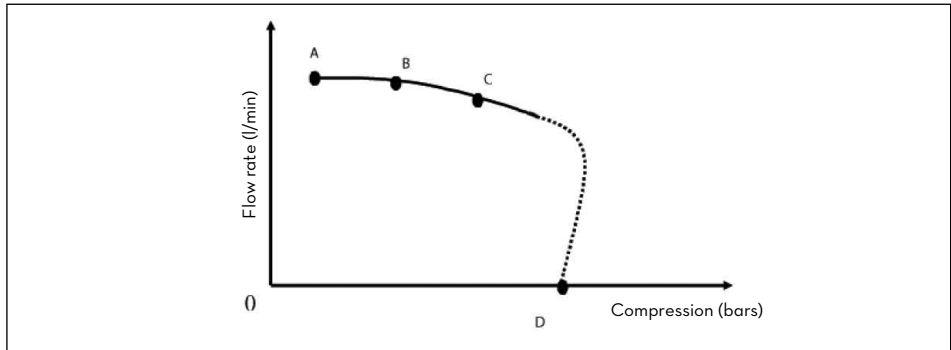

CAUTION: the curve refers to the following operating conditions:
Fluid: Diesel - Temperature: 20 C°

Suction conditions The pipe and position of the pump in relation to the fluid level is such that a negative pressure of 0.3 bar is generated at the rated flow rate.

With different suction conditions, higher negative pressure values can be created which reduce the flow rate due to the back pressure values. To achieve optimum performance it is very important to reduce suction pressure losses to a minimum by following the instructions below:

- keep the suction pipe as short as possible;
- avoid unnecessary bends or restrictions in the pipes;
- keep the suction filter clean;
- use a pipe of suitable diameter.

7 USE

7.1 INTENDED USE

PIUSI 3000 SUPREME is a system designed to manage fluid dispensing for private use. Dispensing management is controlled by the PIUSI SUPREME App. Use for the management of other systems is neither envisaged or permitted.



CAUTION: ambient conditions for use

Ambient temperature: min -20°C / max +50°C.

Relative humidity: max 90%.

The temperature limits indicated apply to the pump components and must be observed to avoid any damage or malfunctions.



WARNING: ELECTRIC CONNECTIONS

THE SYSTEM MUST BE POWERED BY A SAFE SOURCE: BATTERY OR POWER SUPPLY UNIT WITH SAFETY TRANSFORMER.

The rated values of the supply voltages are indicated in the table provided in the heading "TECHNICAL SPECIFICATIONS".



WARNING: WORK CYCLE

The pumps have been designed for continuous use.

The electronic controller progressively reduces the motor rotation speed in order to contain the internal temperature.

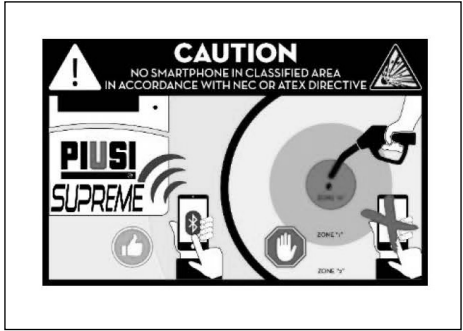

7.1.1 Fluids allowed

TYPE	PIUSI SUPREME
DIESEL at following VISCOSITY	from 2 to 11cSt (at a temperature of 37.8°C) in accordance with UNI EN 590
PARAFFINIC DIESEL	HVO & XTL (GTL/BTL/CTL/PTL) in accordance with standard EN 15940:2019
Flash point (FP)	55°C

7.1.2 Prohibited fluids and relative hazards

TYPE	DANGER
PETROL	FIRE - EXPLOSION
FLAMMABLE LIQUIDS with FP < 55°C	FIRE - EXPLOSION
LIQUIDS WITH VISCOSITY > 20 cSt	MOTOR OVERLOAD
WATER	PUMP OXIDATION
FOOD LIQUIDS	CONTAMINATION OF THE SAME
CORROSIVE CHEMICAL PRODUCTS	PUMP CORROSION - HARM TO PEOPLE
SOLVENTS	FIRE - EXPLOSION - DAMAGE TO SEALS

7.2 IMPROPER USE



CAUTION: it is absolutely forbidden to use mobile phones when dispensing fuel or liquids that emit flammable vapours or that in any case create potentially explosive atmospheres or inside any area classified as an ATEX zone as per current regulations.

Mobile phones must therefore remain outside this area or be switched off.



WARNING: only use the switch on the pump in the event of an emergency!

Do not use the switch as a standard method of stopping the dispensing process.

8 INSTALLATION

8.1 PRELIMINARY CHECKS

- Check that all components are present. Ask the manufacturer for any missing pieces.
- Check that the machine has not been damaged in any way during transport or storage.
- Carefully clean the suction and delivery ports, removing any dust or residual packaging material.
- Check that the electrical data matches the values indicated on the dataplate.
- It is advisable to install a suction filter.

8.2 PUMP POSITIONING



CAUTION: THE MOTORS ARE NOT EXPLOSION-PROOF.

Do not install in areas where flammable vapours may be present.

It is the installer's responsibility to ensure the system is fitted with the accessories needed for the correct and safe use of the pump. Choosing accessories which are unsuitable for the use as described above can cause damage to the pump and/or injury to people and/or pollution.

Install the pump in a well-ventilated place to avoid the build-up of flammable vapours.

The motor must be installed in such a way that correct cooling is ensured: it is advisable to leave at least 30mm of clearance on all sides of the motor casing.

The pump must be firmly secured in place using the fixing bracket provided and the relative fixing screws.

The pump can be installed in a horizontal or vertical position, keeping the electronics compartment cover in a vertical position or facing upwards. This will reduce the risk of water collecting in the electronics compartment.

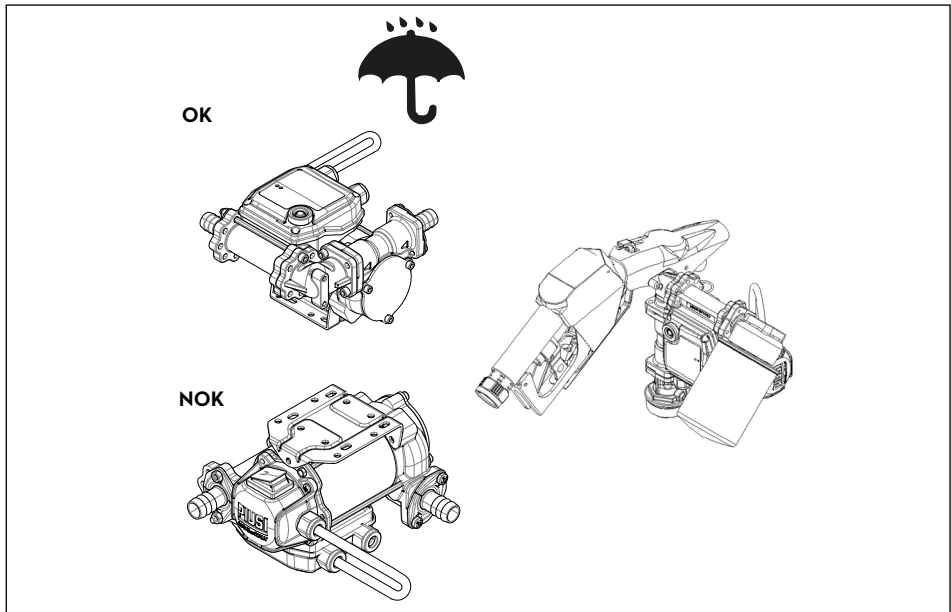

8.3 CONSIDERATIONS CONCERNING THE DELIVERY AND SUCTION LINES

8.3.1 Delivery

The recommended delivery pipe must have a minimum internal diameter of 19mm and a maximum length of 6 metres. The combination of pipe length, pipe diameter, diesel flow rate and the line accessories installed, can create back pressure values that exceed the maximum envisaged values resulting in a significant reduction in the flow delivered.

In such cases, to ensure correct operation of the pump, resistance in the system must be reduced, using shorter and/or wider diameter piping and line accessories with lower resistance (e.g. an automatic nozzle for higher flow rates).

8.3.2 Suction

The recommended suction pipe must have a minimum internal diameter of 19mm and a maximum length of 3 metres. Self-priming type pumps are characterized by a good suction capacity. During the start-up phase, with the suction pipe empty and the pump primed with fluid, the electric pump unit is capable of sucking in liquid with a maximum difference in height of 2 metres. It is important to point out that priming can take for up to 1 minute and that if there is an automatic dispensing nozzle this may prevent the evacuation of air from the installation and therefore impede correct priming.



CAUTION: it is always advisable to carry out priming operations without the automatic nozzle, checking that the pump is priming correctly.

It is always advisable to install a bottom valve to prevent the suction pipe from emptying and to keep the pump primed. In this way, subsequent start-up operations will be immediate.

When the system is in operation, the pump can work with a negative pressure at the suction port of up to 0.5 bar, over which cavitation phenomena may occur resulting in a drop in flow rate and a rise in the level of noise generated by the system. In view of the above, it is important to guarantee low negative pressure at pump intake by using short pipes with a diameter that is equal to or wider than the recommended diameter, reducing bends to a minimum and using large section intake filters and bottom valves with the least resistance possible.



CAUTION: it is very important to keep the suction filters clean because they increase system resistance when clogged.

The difference in height between the pump and the fluid level must be kept as low as possible and in any case within the 2-metre limit envisaged for the priming phase. If this height is exceeded, always install a bottom valve to allow filling of the suction pipe and use pipes with a wider diameter. In any case, it is advisable not to install the pump with height differences exceeding 3 metres.



CAUTION: if the suction tank is higher than the pump, it is advisable to fit a siphon breaker valve to prevent any accidental diesel leakage.

Size the installation in order to contain any overpressure caused by water hammer.

It is good plant engineering practice to install vacuum and pressure gauges immediately upstream and downstream of the pump so that it is possible to verify that operating conditions are within the envisaged range.

8.3.3 Accessories



CAUTION: It is the installer’s responsibility to ensure the system is fitted with the accessories needed for the correct and safe use of the pump.

Choosing accessories which are unsuitable for use as described can cause damage to the pump and/or injury to people and/or pollution.

It is advisable not to use fittings or components that are capable of accumulating static electricity. Should this not be possible, conductive parts may accumulate static electricity that generate annoying but never dangerous electrostatic discharges.

8.4 ELECTRICAL CONNECTIONS



WARNING: Observe the following (non-exhaustive) indications to ensure correct electrical installation:



CAUTION:

- Before performing installation and maintenance operations, always make sure that the power supply lines are disconnected.
- Use cables characterized by minimum sections, rated voltages and type of installation suitable for the characteristics indicated in the heading “TECHNICAL DATA” and for the installation environment.
- DO NOT OPEN the cover on the electronics compartment.
- All electronic components housed within the BP3000 Supreme pump are pre-wired and tested at the factory.
- Consequently, the installer or system manager need NEVER open the electronics compartment.
- The installer must provide a socket/plug connection which allows the electrical system to be rapidly disconnected in the event of any anomalies.



The electrical connections must be carried out in a workmanlike manner by specialised personnel, in full compliance with the regulations in force in the country of installation and with the instructions in the electrical diagrams in this manual.

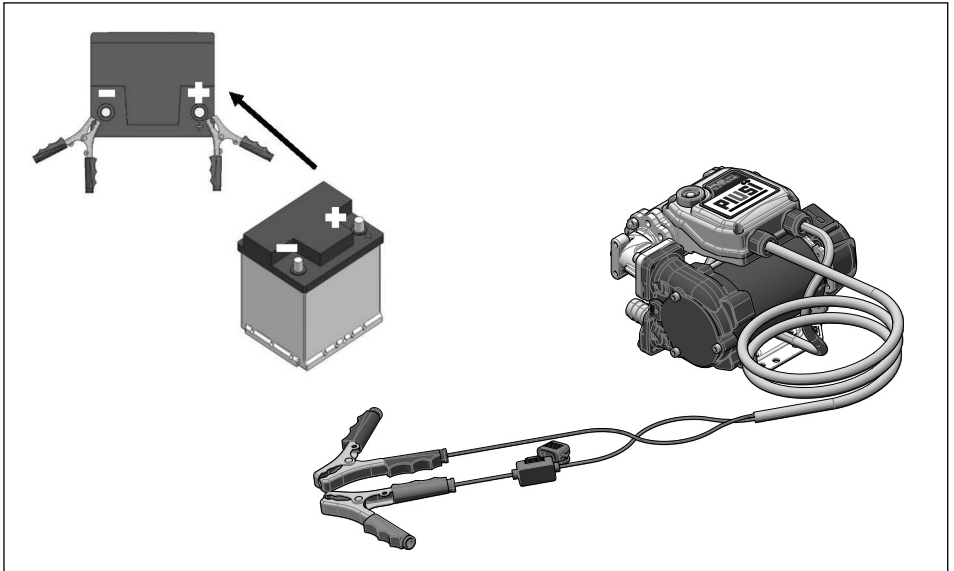

PIUSI 3000 SUPREME comes with a power cable with clamps for connection to the battery. The supplied cable is supplied with a 25A Automotive fuse. For electrical safety purposes, the board is protected against battery connection polarity inversions.



CAUTION:







- Piusi 3000 Supreme does not have the ability to control the battery and does not exercise any type of protection on it.
- If you cut the power cable pliers or manipulate the cable itself, do not remove the protection fuse.

9 FIRST START-UP AND DAILY USE

9.1 FIRST START-UP

After connecting the PIUSI 3000 SUPREME to the battery, the automatic start-up procedure is launched during which the electronic board checks its basic functions.

The two information LEDs on the top cover of the product will light up in the following sequence:

Start-up sequence		1	2	3	4	5
Bluetooth LEDs		10 s				
LED Info		10 s				
Bluetooth LEDs						
LED Info						
LED Info						
LED Info						









At the end of this start-up sequence, all the LEDs go off and the controller is ready for first start-up.

In order to use the product it is necessary to make an initial Bluetooth connection with the controller, using the smartphone App developed by PIUSI.



PIUSI SUPREME App Icon

The App is available for all major Mobile platforms:

 <p>android</p>	<p>Version 7.0 or higher</p>	
<p>iOS</p>	<p>Version 13.0 or higher</p>	
<p>PIUSI SUPREME</p>	<p> NOTE: within the App it is possible to download the user manual or consult it on line. The manual contains all the procedures needed to register the product and for standard use of the system via the App.</p>	
<p>PIUSI SUPREME</p>	<p> NOTE: every time a smartphone connects to PIUSI 3000 SUPREME, the Bluetooth communication LED lights up blue and stays on in fixed mode.</p>	

EN

9.2 FIRST PRIMING

3. Check that the quantity of diesel present in the suction tank is greater than the amount you wish to transfer.
4. Make sure that the remaining capacity in the delivery tank is greater than the amount you wish to transfer.
5. Never dry run the pump as this can seriously damage its components.
6. Make sure that the piping and line accessories are in good condition. Diesel leaks can damage objects and injure people.
7. Never start or stop the pump by switching the power supply on or off.



CAUTION:

- During the priming phase, the pump must discharge from the delivery line all the air initially present in the entire installation. It is therefore necessary to keep the discharge open to allow the air to flow out.
- If an automatic nozzle is installed at the end of the dispensing line, air evacuation may be difficult due to the automatic shut-off device which keeps the valve closed when the line pressure is too low. It is advisable to temporarily remove the automatic nozzle during the first start-up phase.

9.3 DAILY USE

The priming phase may last from just a few seconds up to a few minutes, depending on system characteristics. If this phase goes on longer, stop the pump and check that:

- the pump does not run completely dry;
- the suction pipe is guaranteeing the absence of infiltrations;
- the suction filter is not clogged;
- the suction height does not exceed 2 metres. (if the height is greater than 2 m, fill the suction pipe with fluid);
- the delivery pipe guarantees evacuation of the air;

After priming, verify that the pump is operating within the envisaged range.

PIUSI
SUPREME



NOTE: PIUSI 3000 SUPREME has been designed to be used via a Smartphone using dedicated PIUSI SUPREME Apps.

The use of the i-Button key is to be considered valid only for emergency purposes, in place of the Smartphone.

PIUSI
SUPREME



NOTE: PIUSI 3000 SUPREME is fitted with a safety switch, located on the side of the pump unit, as shown in the following figure.

Make sure the switch is always kept on the I (ON) position when starting the pump.

EN

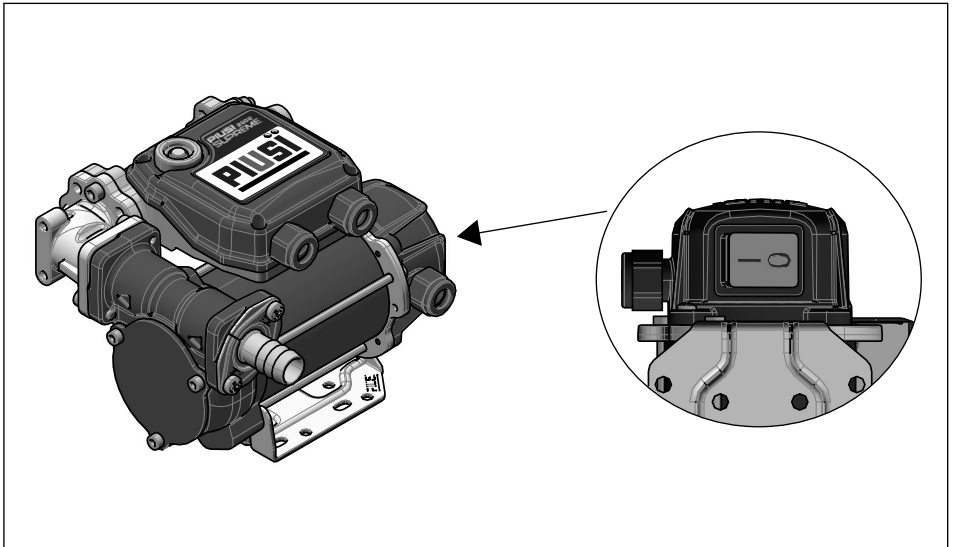

Daily use of the system via the App is described in the section of the on-line manual, as indicated above. As an alternative to using a Smartphone, daily use of the PIUSI 3000 SUPREME can be via the i-Button user key.

In order to use the system with the i-Button key, the system administrator must have correctly registered a user and his relative i-Button key using the App (see the App manual).

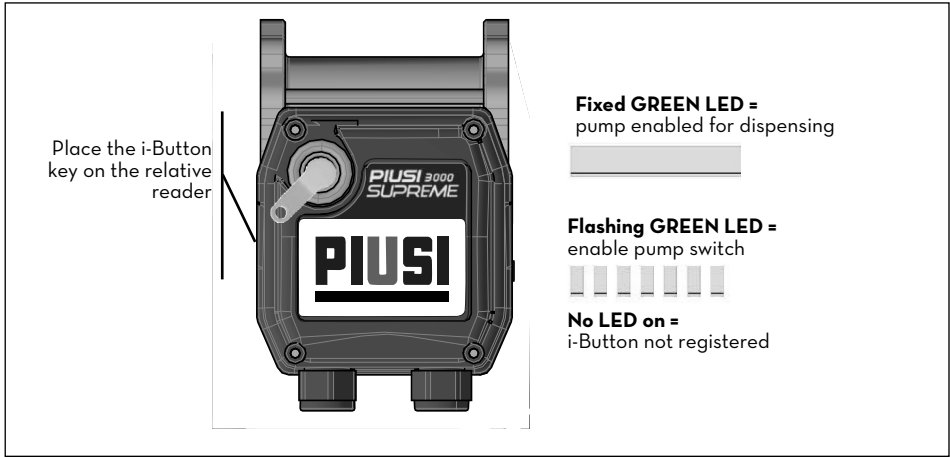

At the end of dispensing, the controller will return to the initial state, with both LEDs off, and will be ready to dispense again.

If you stop dispensing, make sure you cut off the PIUSI 3000 SUPREME power supply.

10 MAINTENANCE

10.1 ROUTINE MAINTENANCE



NOTE: maintenance operations must only be carried out by authorized and adequately trained personnel only.

Always take into consideration the following recommendations for correct use of the pump.

ONCE A WEEK

Check that the pipe connections have not worked loose, to avoid possible leaks.

Check and keep the line filter installed on the suction side clean.

ONCE A MONTH

Check the pump body and keep it clean and free of impurities.

Check that the electrical supply cables are in good condition.

10.2 EXTRAORDINARY MAINTENANCE

CHECK THE FUSES

There is only one safety fuse on the PIUSI 300 SUPREME. This is on the red wire (+ POSITIVE) of the pump power cable.

The fuse supplied is a 25A Automotive type fuse.

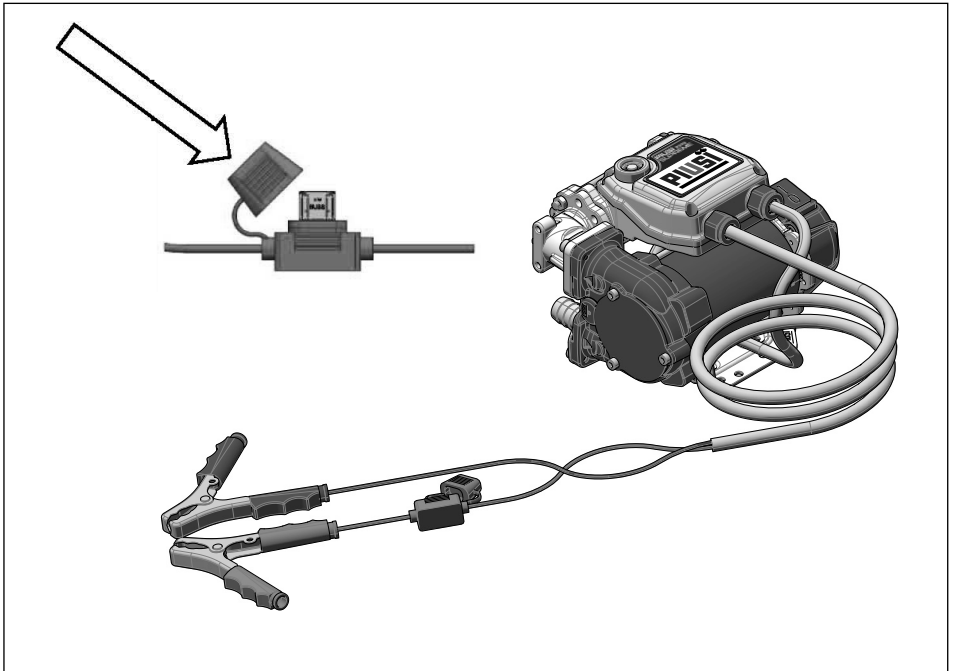

11 TROUBLESHOOTING

11.1 LED SIGNALS AND TROUBLESHOOTING

LED Info		COLOUR / BEHAVIOUR				BLE LED		TYPE DESCRIPTION
								First system start-up in progress. Wait for the two LEDs to go off before using the pump.
								A Smartphone device is connected to the pump.
								Dispensing in progress via i-Button.
								Dispensing in progress via Smartphone.
								Fault detected. Connect with Smartphone for further information.
								Fault detected. Connect with Smartphone for further information.
								Fault detected. Connect with Smartphone for further information.
								Safety Warning Dispensing possible for 5 minutes at low flow rate. Contact your dealer.
								Fault detected. Connect with Smartphone for further information.
								System ready for use.
								Firmware loading in progress.
								The motor switch is in the O (OFF) position. Move the switch to the I (ON) position.

11.2 MECHANICAL AND HYDRAULIC PROBLEMS

PROBLEM	POSSIBLE CAUSES	POSSIBLE SOLUTIONS
The pump does not come on	No power to the electronic board	<ul style="list-style-type: none"> - Check that the 25A fuse located on the power cable is working properly. - Make sure that the electrical connection to the battery is made correctly. - Check the condition of the clamps or terminals.
An operator with an i-Button key not recognised	<ul style="list-style-type: none"> - The key has not been associated with the pump by the system manager. - The key has been damaged and is no longer recognized by the system. 	<ul style="list-style-type: none"> - The manager must associate the i-Button with the driver. - Change i-Button electronic key (THE MANAGER MUST REPLACE THE CODE OF THE OLD KEY WITH THE NEW KEY CODE AND RE-ENABLE THE USER).
The motor will not start	Motor not powered	Make sure the switch is in the I (ON) position.
Counting with dispensing not visible on Smartphone	<ul style="list-style-type: none"> - The user further than 6m away from the pump, or is behind a mass capable of blocking the signal from the pump. - The counting ampoule on the board has been damaged. - The turbine inside the pump has been damaged. 	<ul style="list-style-type: none"> - Move closer to the and see if counting resumes. - If the dispensed value does not increase even when closer to the pump, wait for dispensing to end (Stop Timeout), interrupt it from the App or wait for the preset to be reached.
The pump is dispensing via the App but the App-Pump connection has been interrupted.	<ul style="list-style-type: none"> - Bluetooth was disabled during dispensing. - User has moved too far away from the pump and communication has been interrupted (distance from pump > 6m). 	<ul style="list-style-type: none"> - Wait for the dispensing to finish if a Preset value has been entered. - Close the nozzle and wait for the end of dispensing timer (Stop Timeout). - IN THE EVENT OF AN EMERGENCY, cut off the motor power supply using the relative switch.
App unable to find the pump even though Bluetooth is active	<ul style="list-style-type: none"> - The Bluetooth module on the smartphone is not compatible with the Bluetooth module on the pump. - Pump is being used by another Operator. - The Bluetooth on the Smartphone is engaged by another device. - The Smartphone is too far away from the pump. 	<ul style="list-style-type: none"> - The Bluetooth module on the pump is compatible with all Smartphones that feature Bluetooth version 6.0 or later (Smartphones from 2015 onwards) - The pump will become visible on the Smartphone only after the operator who is using the pump has finished. - Terminate connection with other device. - Move closer to the device.

PROBLEM	POSSIBLE CAUSES	POSSIBLE SOLUTIONS
The count is not accurate	System is NOT calibrated.	Calibrate the system according to the procedure reported in the App manual.
	Low level in the suction tank.	Fill the tank.
	Bottom valve blocked.	Clean and/or replace the valve.
	Filter clogged.	Clean the filter
	Excessive suction pressure.	Lower the pump in relation to the level of the tank or increase the cross-section of the piping.
	High loss of head in the delivery circuit (working with the by-pass open).	Use shorter tubing or of greater diameter.
	By-pass valve blocked.	Disassemble the valve, clean it or replace it.
	Air entering the pump or the suction piping	Check tightness of the connections.
	A narrowing in the suction tubing.	Use tubing suitable for working under suction pressure.
	Low rotation speed.	Check the voltage at the pump; adjust the voltage and/or use cables of greater cross-section.
	Suction piping resting on the bottom of the tank.	Lift the piping.
Dispensing is set to LOW-FLOW mode.	Check that dispensing has not been set to LOW-FLOW if not desired.	
Excessive noise	Irregular functioning of the by-pass.	Dispense until the air is purged from the by-pass system.
	Presence of air in the diesel.	Check the suction connections.
	Abnormal restrictions along the system.	Check the fluid connections.
Leaks to the outside	Seal damage.	Check seal and replace if necessary.

12 SCRAPPING AND DISPOSAL

FOREWORD

In case the system should be demolished, its parts must be given to companies specialised in industrial waste disposal and recycling; in particular:

PACKAGING DISPOSAL

The package is made of biodegradable cardboard that can be consigned for sorted waste collection.

DISPOSAL OF METAL PARTS

The metal components, both painted and in stainless steel, are usually recycled by companies that are specialised in the metal-scraping industry.

DISPOSAL OF ELECTRICAL AND ELECTRONIC EQUIPMENT

Disposal of waste electrical and electronic equipment must be handled by specialised recycling and disposal companies in compliance with the provisions of directive 2012/19/EU.

It is strictly prohibited to discard waste electrical and electronic equipment (WEEE) as household waste. Such wastes must be disposed of separately.

Any hazardous substances in the electrical and electronic appliances and/or the misuse of such appliances can have potentially serious consequences for the environment and human health.

Unlawful disposal of WEEE may result in application of the penalties provided for in law.

ENVIRONMENTAL INFORMATION FOR CUSTOMERS RESIDENT IN THE EUROPEAN UNION

European Directive 2012/19/EU requires that equipment bearing this symbol on the product and/or its packaging must not be disposed of with unsorted municipal waste.



The symbol indicates that this product must not be disposed of as household waste. It is your responsibility to dispose of this and other electric and electronic equipment via designated collection facilities appointed by the government or local authorities.

DISPOSAL OF OTHER PARTS

13 REPLACEMENT PARTS TABLE

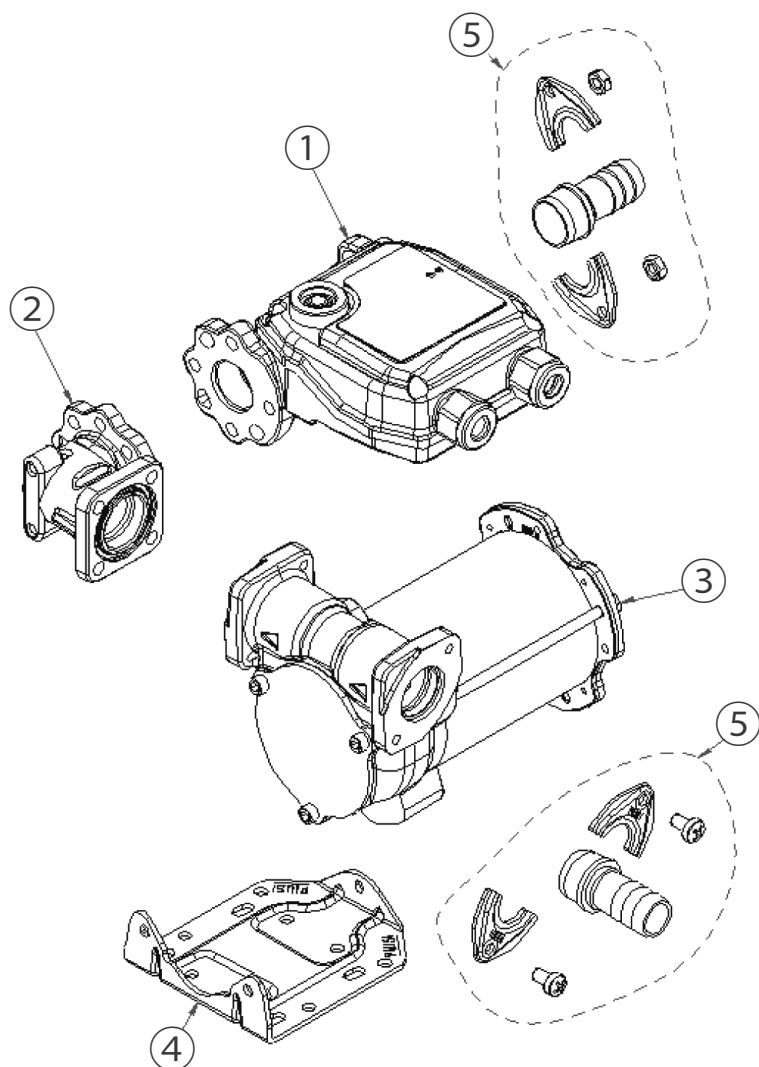

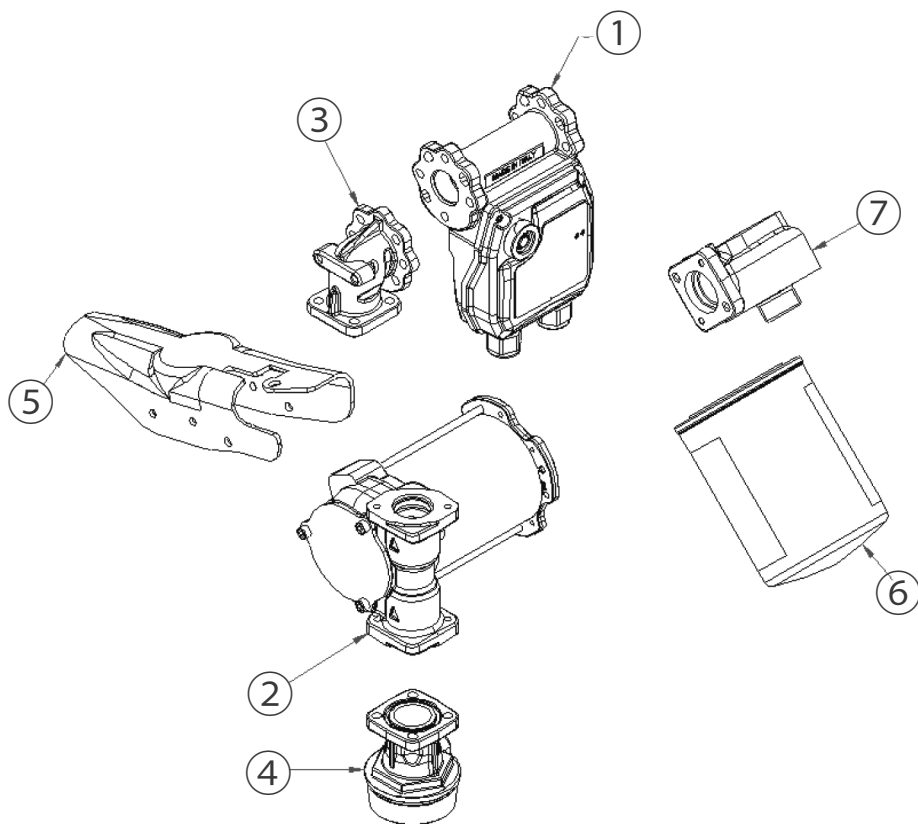



*Fluid Handling
Innovation*

IT Scarica il manuale nella tua lingua!
EN Download the manual in your language!
CS Stáhnout příručku ve vašem jazyce!
DA Download manualen på dit sprog!
DE Laden Sie das Handbuch in Ihrer Sprache herunter!
ES ¡Descarga el manual en tu idioma!
FI Lataa käsikirja omalla kielelläsi!
FR Téléchargez le manuel dans votre langue!
NL Download de handleiding in uw taal!
PL Pobierz instrukcję w swoim języku!
PT Baixe o manual em seu idioma!
RU Загрузите руководство на вашем языке



<https://www.piusi.com/support/search-manuals>

piusi.com
PIUSI SpA • Suzzara MN Italy