

OPERATING INSTRUCTIONS AND SAFETY NOTES

AdBlue[®] electric diaphragm pump

230 V 1~AC

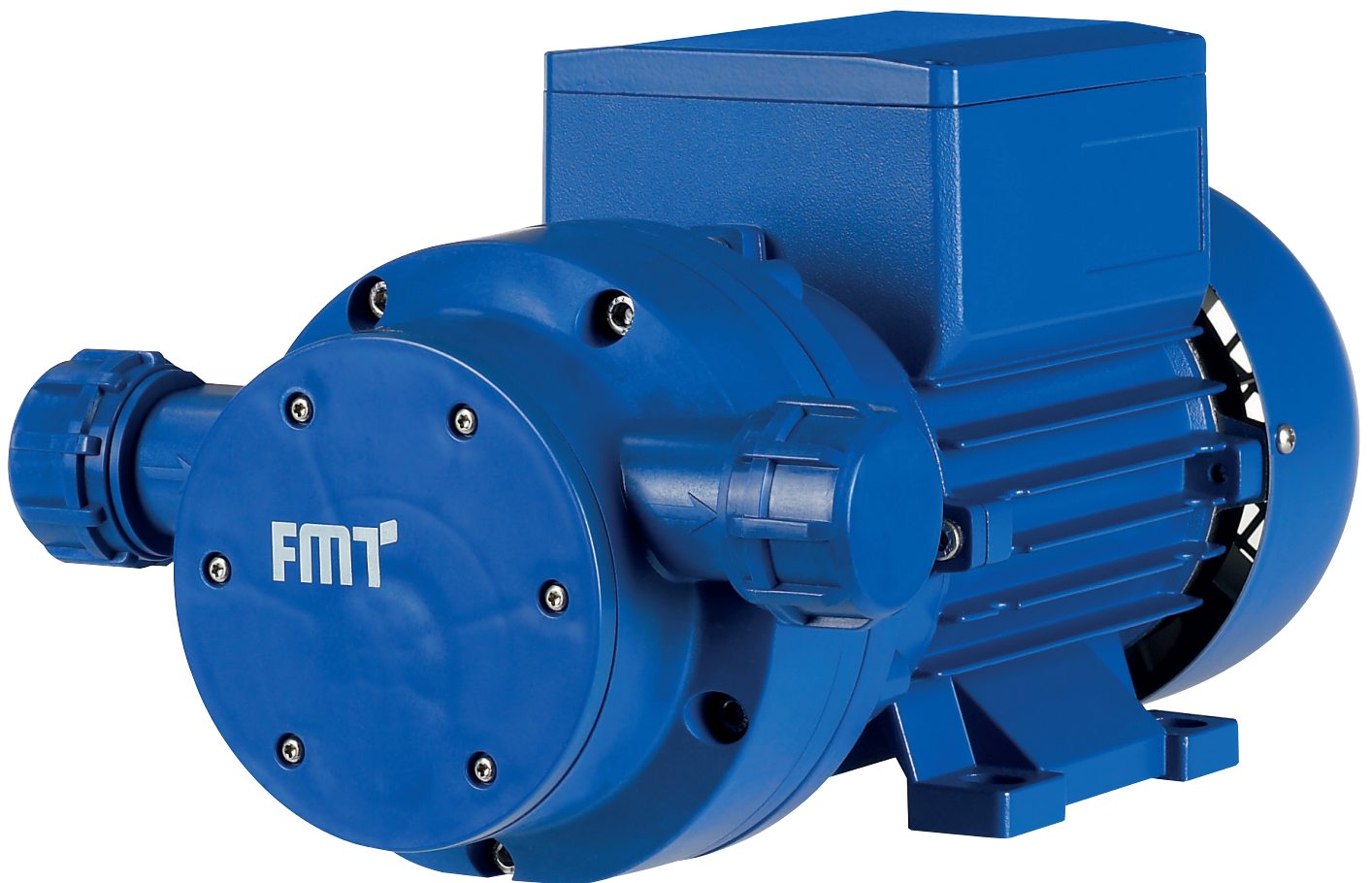

FMT Swiss AG

This documentation is exclusively intended for the operating company and their staff.

Without our written consent, the content of this documentation (textes, figures, drawings, charts, diagrams etc.), must not be duplicated or distributed, neither in full or in part, utilized for the purpose of competition or passed on/made available to third parties.

FMT Swiss AG

Fluid Management Technologies Swiss AG

Gewerbestraße 6

6330 Cham / Switzerland

Tel. +41 41 712 05 37

Fax +41 41 720 26 21

Email: info@fmtag.com

Internet: www.fmtag.com

Operating instructions translation

Date of issue: 10/2020

We reserve the right to make design and product modifications, which serve to improve the product.

Table of Contents

1.	Introduction	4
1.1.	Preface	4
1.2.	Obligations of the personnel	4
1.3.	Symbols in this manual	4
1.3.1.	Structure of the safety notes	4
1.3.2.	Hazard warning symbols	5
1.3.3.	General symbols	5
2.	Safety notes	5
2.1.	Authorized personnel	6
2.2.	Notes for maintenance, cleaning and repair	6
2.3.	Intended conditions of use	6
2.4.	Risks when handling the AdBlue® electric diaphragm pump	7
2.5.	Risks in handling AdBlue® solutions	7
3.	Transport and temporary storage	8
4.	Design and functional description	8
4.1.	Area of application	8
5.	Technical data	8
6.	Installation	9
7.	Commissioning and operation	9
8.	Preventive maintenance	10
9.	Maintenance	10
10.	Troubleshooting	11
11.	Repair/Service	11
12.	Disposal	11
13.	EC Declaration of Conformity	12
14.	Mounting dimensions of electric diaphragm pump	13
15.	Exploded view of AdBlue® electric diaphragm pump	14
16.	Overview of components of AdBlue® electric diaphragm pump	15
17.	Pump sets for assembly on IBC containers	16
17.1.	Design	16
17.2.	Assembly on an IBC container	17
18.	Pumps sets with filter for assembly on IBC containers	18
18.1.	Design	18
18.2.	Assembly on an IBC container	19
19.	Pump sets for assembly on a barrel	20
19.1.	Design	20
19.2.	Assembly on a barrel	21

1. Introduction

1.1. Preface

Please carefully read these operating instructions and observe in particular all safety notes!

Our staff will be pleased to provide support if you have any questions about the product.

Yours sincerely, FMT Swiss AG

1.2. Obligations of the personnel

Before they start to work, all persons who are entrusted to work with the AdBlue® electric diaphragm pump, are obliged:

- to follow all applicable regulations on occupational safety and accident prevention.
- to read and to comply with all safety instructions and warning notes contained in these operating instructions.

Please observe the following instructions in the interest of all concerned:

- Refrain from any unsafe working methods!
- Adhere to all hazard and warning notes contained in this manual!
- In addition to this documentation, keep to all generally accepted safety rules, legal provisions as well as all other binding rules regarding occupational safety, accident prevention and environmental protection!
- Wear appropriate protective clothing in accordance with the work to be done!
- Perform only work for which you have been sufficiently trained and instructed!
- Only genuine spare parts as well as original tools and auxiliaries of the manufacturer are allowed to be used in order to ensure the functional safety and maintain the warranty coverage.

1.3. Symbols in this manual

1.3.1. Structure of the safety notes

The warning notes have the following structure:



SIGNAL WORD

Type and source of the hazard

- Consequences of non-compliance with the notes
- Measures to avoid that risk

Depending on the danger level, different signal words are used:

Signal word	Danger level	Consequences of non-compliance
DANGER	Imminent threat of danger	Death or serious bodily injury
WARNING	Possible threat of danger	Death or serious bodily injury
CAUTION	Possibly dangerous situation	Minor bodily injury
ATTENTION	Possibly dangerous situation	Damage to material property



NOTE

Indicates further information or tips which facilitate work

1.3.2. Hazard symbols

Symbol	Meaning
	General hazard symbol. The warning note marked in this way contains supplementary information on the type of hazard.
	This symbol warns of dangerous electrical voltages
	This symbol warns of a hazardous explosive atmosphere

1.3.3. General symbols

Symbol	Meaning
■	A small black square indicates the work you have to perform
–	The dash denotes lists
⇒	The arrow identifies cross-references. If cross-references to other chapters are required within the text, the expression is shortened for reasons of clarity. Example: ⇒ Chapter 2 Safety instructions This means: please refer to chapter 2 for the safety instructions

2. Safety instructions

Various dangers may occur if the AdBlue® electric diaphragm pump is improperly handled during installation, commissioning and daily operation.



WARNING

Risk of injury and damage to material property because of improper handling

- Hold the manual at the disposal of the operating staff at the usage site of the unit.
- Country-specific safety measures and accident prevention regulations must be observed.

2.1. Authorized personnel

Only qualified and authorized persons are allowed to operate and to work on the AdBlue® electric diaphragm pump.

Persons are qualified if they are, due to their training, experience, instruction and knowledge of the relevant standards, able to assess assigned tasks and to identify potentially hazardous situations.

These persons must have been authorized by the person responsible for the safety of the unit and must be able to identify and to avoid potential dangers.

All persons charged with installation, operation, maintenance and repair work, must have read and understood this operation manual.

A copy of this operating manual must be stored permanently and ready at hand at the place of usage of the unit.

2.2. Notes on maintenance/cleaning and repair



WARNING

Risk of injury and damage to material property because of improper maintenance and repair

- Keep to the specified inspection and maintenance intervals (⇒ **chapter Maintenance**).
 - Should unusual noises occur, immediately stop the electric diaphragm pump. Immediately identify and eliminate the cause in order to avoid consequential damages.
 - Observe the safety sheet for AdBlue®.
-

2.3. Intended conditions of use

The AdBlue® electric diaphragm pump is to be used only for the delivery of AdBlue® and water.

The temperature of the conveying liquid must be between -5 °C and + 35 °C.

The AdBlue® electric diaphragm pump is only allowed to be connected to a suitable power source (see nameplate).

To ensure that usage stipulations are met, read through the Operating Instructions completely before using the pump and observe all stipulations.

Any departure from the usage stipulations (other fluid media, use of force) or user modifications (changes, use of non-original parts) can be dangerous and are considered as non-intended usage.

The user is liable for any damage resulting from non-intended use.

During repairs to any electrical components, the appropriate safety and test requirements are to be observed.

Only genuine replacement parts are to be used for any repairs, because otherwise the warranty will be invalidated.

In order to prevent dirt from entering the pump chamber, it is absolutely necessary to install a strainer with pre-cleaner in the suction line, because otherwise the warranty may be invalidated.

Any application beyond the intended use can lead to hazardous situations and shall be regarded as non-intended use.



DANGER

Risk of injury and material damage from explosive vapors!

- **Never use the pump to deliver explosive fluids such as petrol or other fluids with similar flashpoints.**
- Since the motor and the switch are not explosion-protected, the pump must **not** be operated in an explosion risk area.

2.4. Risks when handling the AdBlue® electric diaphragm pump



DANGER

Risk of injury and material damage because of improper installation, electric current or contaminated media

Never work on a pump that is running

- Mount or remove attachments and accessories only when the pump is switched off.
- For your own safety, disconnect the pump in addition from the power supply.

Do not pump contaminated fluids

- Take special care to ensure that there are no contaminants in the fluid to be pumped.
- Install a strainer on the suction pipe.

Damaged attachments and accessories can lead to personal injury and material damage

- Attachments and accessories must be checked for wear, splits or other damage throughout their period of use.
- Damaged accessories and attachments must be replaced immediately.
- With reference to the period of use, please note the details in ZH 1/A45.4.2 or DIN 20066 Part 5.3.2.

Escaping liquids can cause environmental harm.

Comply with the stipulations of the German Water Resources Act (WHG) and of the Plant Regulations of the German federal states.

2.5. Risks in handling AdBlue® solutions

The AdBlue® concentrate is not inflammable, not explosive and not oxidizing.



NOTE

For cleaning, flush equipment with water. Dispose of released contaminated fluid according to the statutory provisions. In general, dilution with water is sufficient.

AdBlue® is corrosive to non-ferrous metals.

Avoid skin and eye contact. In case of contact with the eyes, rinse the eyes with plenty of drinking water and consult a physician.

Observe the safety sheet for AdBlue®.

3. Transport and temporary storage

Do not use the cable to transport the pump!

Storage and transport conditions:

- Weather-protected storage with temperature control, protection against frost, moisture and rain.
Maximum relative humidity: 80 %.
- Storage temperature range from -5 °C to + 55 °C.

4. Construction and functional description

The self-priming pump is compact and handy. A wide range of FMT accessories are available for quick and easy mounting on each installation.

The materials of the pump are compatible with slightly aggressive liquids like AdBlue®.

The pump is electrically driven by an alternating current motor suitable for continuous operation. The pump is directly flange-mounted to the motor. In case of overload, a thermal protection device automatically switches off the motor.

When the motor has cooled down, the thermal protection device automatically restarts the motor.

Pump data ⇒ chapter Technical Data.

The AdBlue® electric diaphragm pump is available in the following versions:

- **AdBlue® electric diaphragm pump, 230 V, 50 Hz, 35 l/min.**
- **AdBlue® electric diaphragm pump, 230 V, 50 Hz, 14 l/min.**

4.1 Area of application

The AdBlue® electric diaphragm pump is only suitable for the delivery of AdBlue® and water.

The temperature of the delivery fluids must be between -5 °C and +35 °C. The temperatures must not be above or below these limit values.

Since the motor and the switch are not explosion-protected, the pump must **not** be operated in an explosion risk area.

5. Technical data

Designation	230 V	230 V
	25 280	25 284
Power cable length (m)	2,8	2,8
Connection suction side	G 1" male	G 1" male
Connection discharge side	G 1" male	G 1" male
Hydraulic data		
Pump design	Diaphragm pump, self-priming	Diaphragm pump, self-priming
Delivery rate under free discharge (l/min)	35	14
Suction height (m)	3	3
Discharge pressure up to (bar)	1,7	1,7
Pumping media	AdBlue®, water	AdBlue®, water
Motor data		
Voltage (V)	230	230
Frequency (Hz)	50	50
Power consumption (A)	1,5	1,5
Power (kW)	0,36	0,36
Thermal protection	self resetting	self resetting
Rotation speed (rpm)	2800	2800
Type of construction	IMB 3	IMB 3
Protection class	IP 66	IP 66
Material diaphragm and sealings	EPDM/FKM	EPDM/FKM
Material pump housing	PA 6 GF 30	PA 6 GF 30
Dimensions L x W x H (mm)	310 x 180 x 160	310 x 180 x 160
Weight (kg)	6,86	6,86

Tab. 5.-1: Technical data

6. Installation

The AdBlue® electric diaphragm pump is designed for installations in indoor and outdoor areas.

For outdoor installation, a housing is required as protection against the effects of weather.

4 screws with a diameter of less than 7 mm are required to fasten the AdBlue® electric diaphragm pump (not contained in the scope of delivery).

When installing the pump, ensure that it is mounted on a stable surface. Select a secure location (protected from splash water, damage and theft).

- Remove the plastic plugs from the suction and discharge junctions.
- Fix the hoses to the suction and delivery connectors. Attach the strainer to the end of the suction hose.
- Attach the nozzle valve to the delivery hose.
- Use the mains plug to connect the pump to a power source: 230 V/50 Hz.
- Lay the power cable in a way that avoids any risk of stumbling.



NOTE

Ensure cleanliness during installation and an exact connection of the accessories with the pump housing.

7. Commissioning and operation

Check the operativeness of the electric diaphragm pump before use and after a failure-related or scheduled downtime.

Check the AdBlue® electric diaphragm pump and the installed accessories for completeness and damage. Replace any damaged components immediately. Never use a pump if damaged.

Check the suction strainer for damage each time the tank is filled/emptied and replace it if damaged. Never operate the pump without the suction strainer because otherwise the AdBlue® electric diaphragm pump will not be protected against contamination by foreign bodies.

- Hang the suction hose into the container to be emptied.
- Hold the nozzle valve into the container to be filled.
- Operate the rocker switch to switch on the pump.



CAUTION

- Never operate the pump without liquid. The AdBlue® electric diaphragm pump may be damaged by running dry.
- The bypass valve allows operation with closed delivery line only for a short period (for a maximum of 3 minutes).

Press the nozzle valve lever up according to the delivery rate required, or lock it in position for constant flow (only applicable to automatic nozzle valve, not included in standard delivery).



CAUTION

- The AdBlue® electric diaphragm pump does not switch off automatically, therefore when filling, never let the pump running without supervision.

- For finishing the filling operation, release the nozzle valve control lever. Never operate the pump for longer than 3 min with closed nozzle valve.
- Operate the rocker switch to switch off the pump.
- Position the nozzle valve so that no media can pollute the environment.



CAUTION

Danger of product damage

- The power source must be of the correct voltage for the pump type.

8. Preventive maintenance

In general, the AdBlue® electric diaphragm pump is very easy to maintain and to service.

Due to the operator responsibilities according to § 19i WHG (German Water Resources Act) the following components must be regularly checked and replaced as necessary to minimise the risk of environmental or equipment damage or personal injury:

- Pump housing
- Delivery hose
- Nozzle valve

9. Maintenance

Maintenance must be done by qualified technical personnel. External impact may cause a loss of performance, constitute a risk of damage to persons and/or property and void the guarantee.



DANGER

Direct contact with energized components during various work activities

- For all work, the pump switch must be set to neutral position.
- Maintenance work may only be done by qualified specialists.

Observe the following recommendations for operating the pump:

- Before performing any maintenance work, disconnect the AdBlue® electric diaphragm pump from all electric and hydraulic supply sources.
- Always wear personal protective equipment when carrying out maintenance work.
- If there is danger of freezing, the pump and the circuit must be emptied and stored at a location with a temperature not lower than 0 °C/32 °F.
- Check to ensure that the labels and decals have not become illegible and have not come loose in the course of time.
- Check at regular intervals that the line connections have not worked loose in order to avoid that liquid escapes.
- Regularly check and clean the suction line filter.
- From time to time, check the pump housing and remove any dirt.
- Check to ensure that the power cables are in perfect working order.
- If the pump is planned to be put out of operation for more than 15 days, completely empty the pump and the system in order to prevent the AdBlue® from crystallizing inside the pump system. Finally, thoroughly clean the pump and the system.

10. Troubleshooting

Malfunction	Cause	Solution
Motor does not run	▶ No power supply	▶ Check the electric connections
Discharge rate too low	▶ Discharge hose kinked or clogged ▶ Suction line resistance too high ▶ Filter resistance too high ▶ Nozzle valve not completely open	▶ Check the discharge hose ▶ Suction line too long, kinked, clogged or too many bends ▶ Check the suction filter and the check valve ▶ Check and clean the suction filter ▶ Completely open the nozzle valve
Pump runs too loudly	▶ Air entry in the suction line ▶ Feed quantity too low ▶ Suction tank without pressure compensation	▶ Check the airtightness in the suction line ▶ Tank almost empty or empty ▶ Dirty suction filter ▶ Sufficiently ventilate suction tank, for example by means of FMT vent valve (45 150)
Leak	▶ Defective diaphragm ▶ Defective O-Ring	▶ Replace the diaphragm kit (80 864) ▶ Replace the O-ring (82 869)
Pump rotates with difficulty	▶ Deposits or foreign materials in the pump ▶ Pump is frozen (Temperature too low)	▶ Clean the pump ▶ Let thaw the pump and check it for damage. Operating the pump at a too low temperature may lead to damages at the pump or at the motor

Tab. 10.-1: Troubleshooting

11. Repair/Service

The AdBlue® electric diaphragm pump was developed and produced according to the highest quality standards.

Should a problem develop, despite all quality controls, please contact our customer service:

FMT Swiss AG

Tel +49 9462 17-246

Fax +49 9462 1063

service@fmtag.ch

12. Disposal

The operating company is responsible for the proper disposal of the pump.

Hereby, the industry-specific and local regulations must be observed when disposing of the pump.

Only qualified personnel is authorized to disassemble and dispose of AdBlue® electric diaphragm pump.

13. EC Declaration of Conformity



Manufacturer:

FMT Swiss AG

Fluid Management Technologies Swiss AG

Gewerbestraße 6

6330 Cham / Switzerland

Declares under his sole responsibility that the machine:

Model type	AdBlue® electric diaphragm pump 25 280/25 284 (230 V)
Motor voltage	230 V
Power	230 V - 0,36 kW
Function	Conveying of AdBlue® and water
Complies with all relevant provisions of the following Directive:	
EC Directives	2006/42/EG Machinery Directive 2014/30/EU EMC Directive 2011/65/EU EU-Directive (RoHS)
Applicable standards	EN 809; EN ISO 4144; EN 60204-1 EN 12100:2010; EN 55011; EN 61000-2-4

Authorized representative for the compilation of the technical documentation:

Name: Manuel Bredenbruch
 Address: Fluid Management Technologies Swiss AG
 Gewerbestraße 6
 6330 Cham / Switzerland
 Phone: +49 09462/ 17 -218

FMT Swiss AG
 Cham, 22.01.2018

Dipl.-Ing. Rudolf Schlenker
 (Managing Director)

14. Mounting dimensions of AdBlue® electric diaphragm pump (in mm)

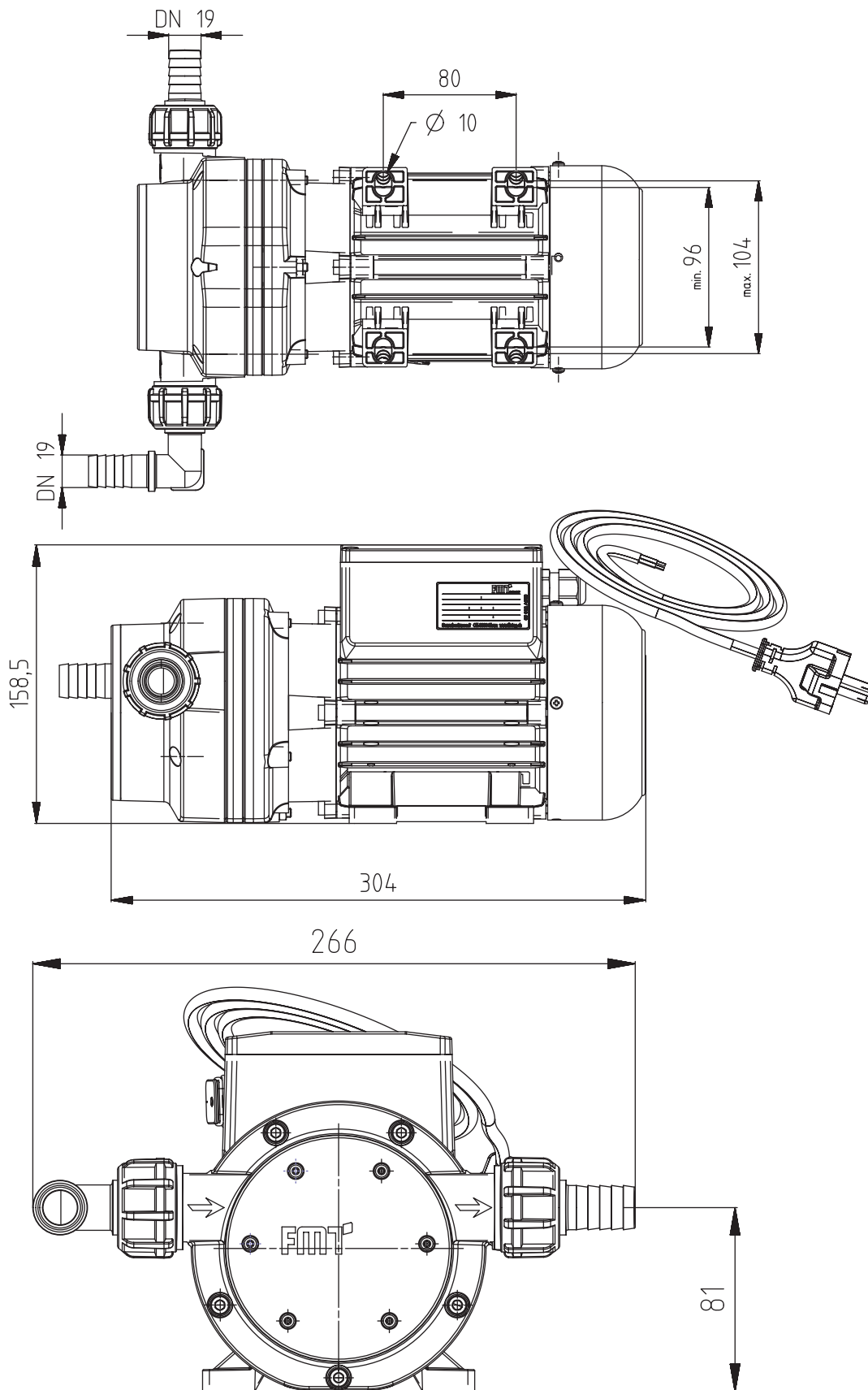

Fig. 14. -1: Mounting dimensions of AdBlue® electric diaphragm pumps (in mm)

15. Exploded view of AdBlue® electric diaphragm pump

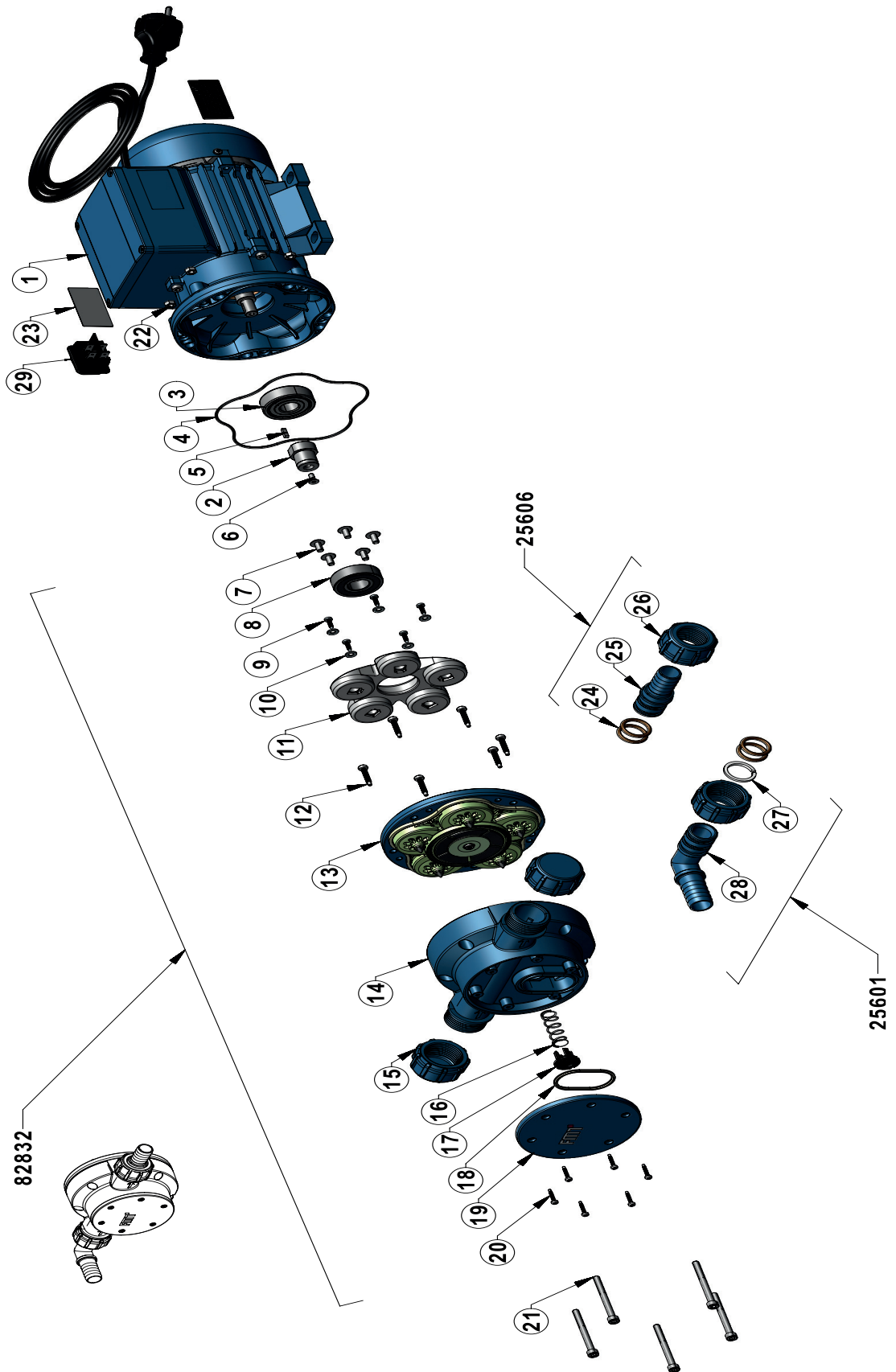

Fig. 15.-1: Exploded view of AdBlue® electric diaphragm pump

16. Overview of components of AdBlue® electric diaphragm pump

Pos.	Quantity	Description	Item number
1	1	Motor painted blue 35 l/min	83 705
2	1	Eccentric flange for 50 Hz	82 864
3	1	Ball bearing-DIN625-1 6302-2Z	82 867
4	1	O-Ring-FKM 70-Ø120x2	82 869 878
5	1	Feather key DIN 6885 A	00 602
6	1	Countersunk screw M 4x10	84 012
7	5	Screw M 5x10	80 730
8	1	Ball bearing DIN625-1 6203 2Z	82 855
9	5	Fillister head screw STSplus	82 845
10	5	Tension plate DIN6796-Ø4	82 846
11	1	Swash cross	82 844
12	6	Plastic screw 4x22	86 768
13	1	Membrane spare part for AdBlue® electric diaphragm pump 35 l/min	80 864
	1	Membrane spare part for AdBlue® electric diaphragm pump 14 l/min	80 864 020
14	1	Pump housing	82 833
15	2	Screw cap G1 blue	82 857 001
16	1	Bypass spring	82 836
17	1	Bypass valve	82 837
18	1	X-Ring EPDM 37,77x2,62	86 985
19	1	Cover	82 834
20	6	Plastic screw 3x16	86 769
21	5	Cylinder screw M 5x55	86 893
22	5	Hexagonal nut DIN 934	86 773
23	2	Plate	89 882
24	4	O-Ring FKM 80 - 19,2x3	82 859 878
25	1	Nipple	82 858
26	2	Nut G1 blue	82 857
27	1	Circlip	82 862
28	1	Angle 90 straight	82 861
29	1	Waterproof switch	81 293

Tab. 16.-1: Overview of components for fig. 15.-1

17. Pump sets for assembly on IBC containers

17.1. Design

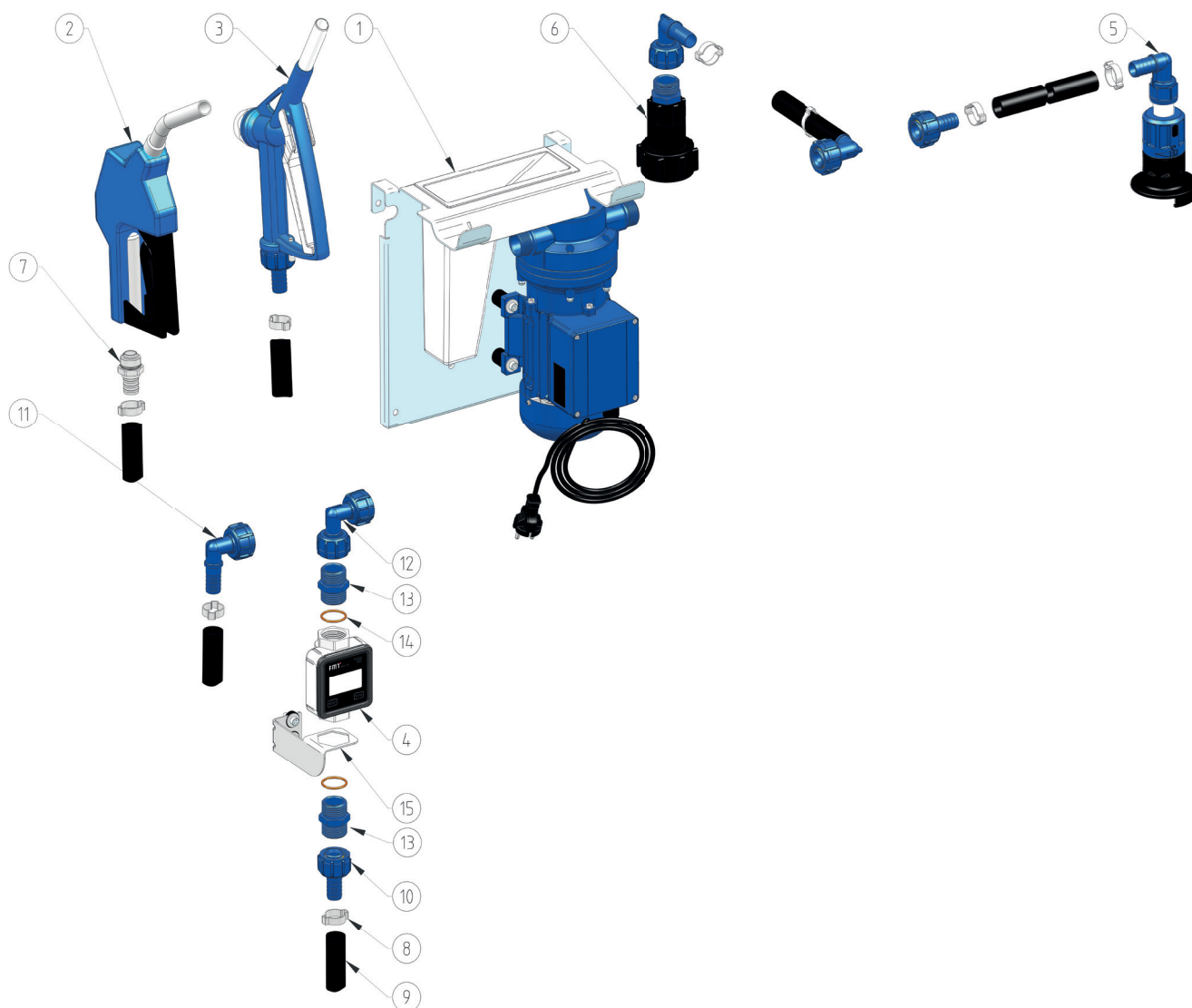

Fig. 17.-1: Design

Pos. Description

1	Mounting bracket for IBC
2	Automatic nozzle valve-AdBlue®
3	Mechanical nozzle valve-AdBlue®
4	In-line meter, digital
5	SEC adaptor for IBC
6	IBC adaptor for AdBlue® tanks
7	Swivel joint DN 19-stainless steel
8	2 ear hose clamp

Pos. Description

9	Discharge hose
10	Hose fitting
11	Bend 90° with fitting
12	Bend 90° with 2 x union nut
13	Double nipple
14	O-ring FKM 80
15	Meter holder for IBC set AdBlue®

Tab. 17.-1: Overview of the individual parts of fig. 17.-1

17.2. Assembly on an IBC container

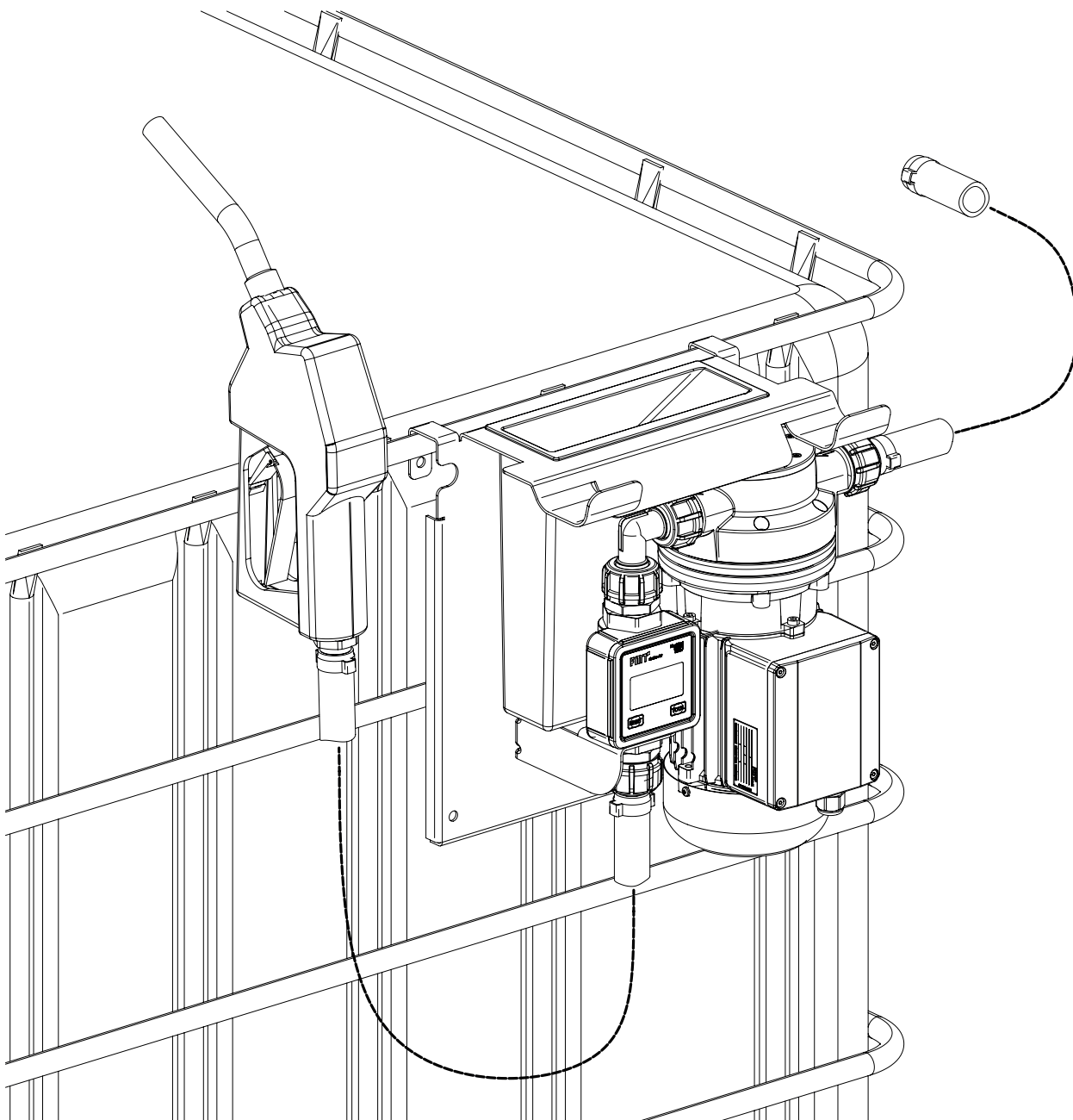

Fig. 17.-2: Assembly on the IBC container



CAUTION

- Ensure a stable and safe fastening of the discharge system during each installation.

18. Pumps sets with filter for assembly on IBC containers

18.1. Design



Fig. 18.-1: Design

Pos.	Description	Pos.	Description
1	Support plate with clinch stud	4	SEC adaptor for IBC
2	Automatic nozzle valve-AdBlue®	5	Swivel joint DN 19 - stainless steel
3	Adapter M64 x 4	6	Bend 90° with fitting

Tab. 18.-1: Overview of the individual parts of fig. 18.-1

18.2. Assembly on an IBC container

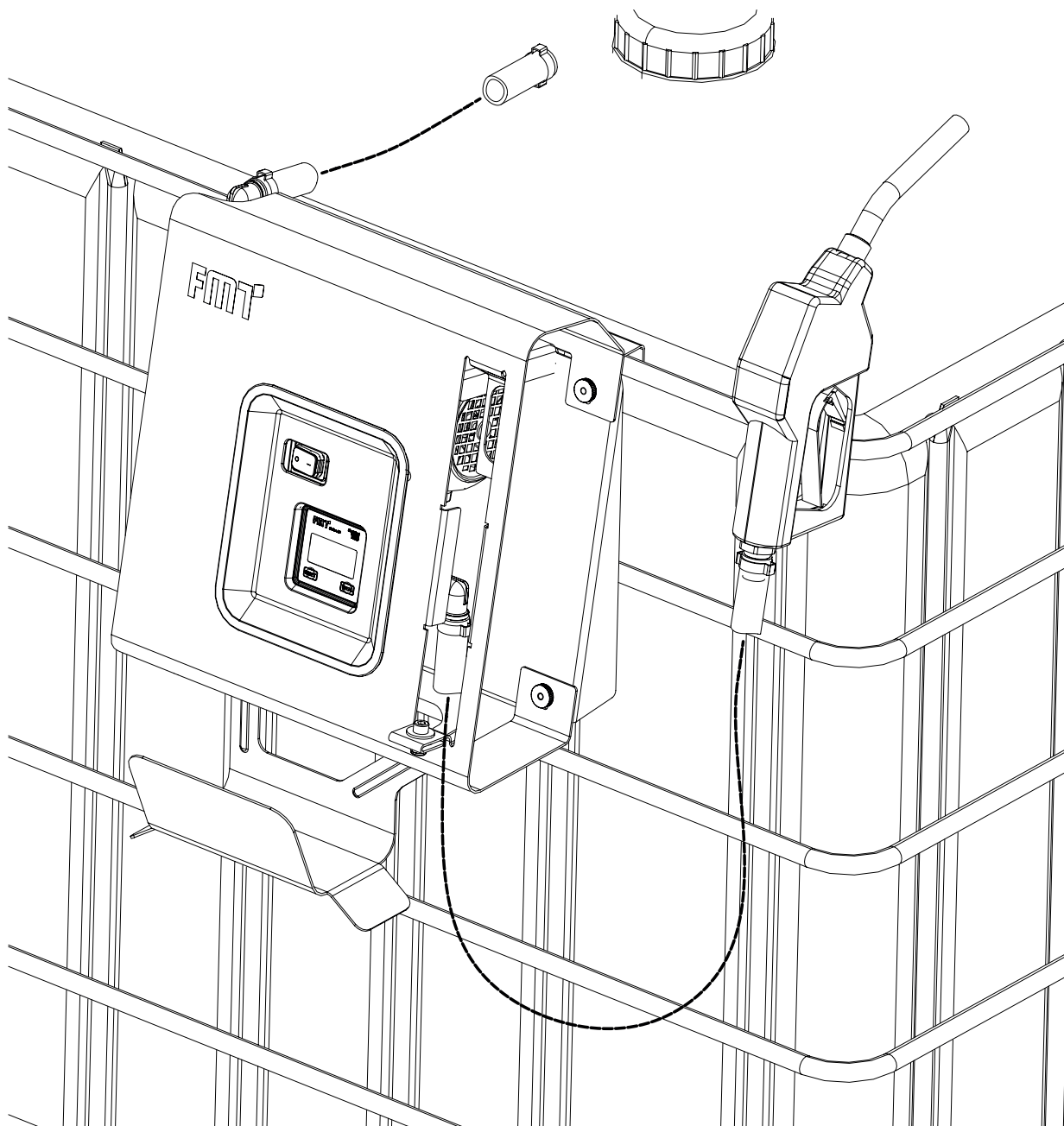

Fig. 18.-2: Assembly on the IBC container



CAUTION

- Ensure a stable and safe fastening of the discharge system during each installation.

19. Pump sets for assembly on a barrel

19.1. Design

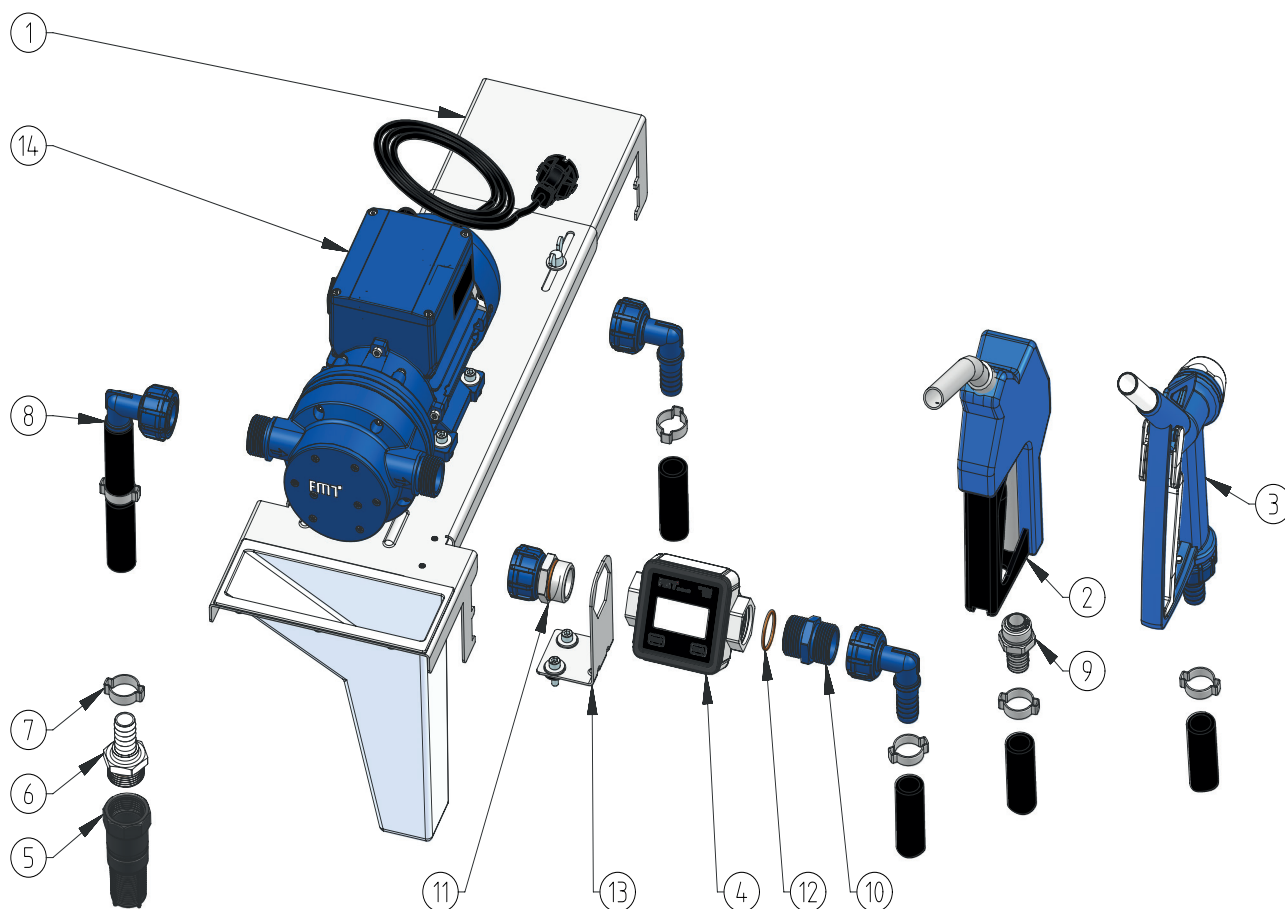

Fig. 19.-1: Design

Pos.	Description	Pos.	Description
1	Telescopic mounting bracket	8	Bend 90° with fitting
2	Automatic nozzle valve-AdBlue®	9	Swivel joint DN 19 - stainless steel
3	Mechanical nozzle valve-AdBlue®	10	Double nipple
4	In-line meter, digital	11	Connection fitting short
5	Foot valve with filter	12	O-ring FKM 80
6	Threaded fitting DN 19	13	Meter holder for telescopic mounting bracket
7	2 ear hose clamp	14	AdBlue® electric diaphragm pump

Tab. 19.-1: Overview of the individual parts of fig. 19.-1

19.2. Assembly on a barrel

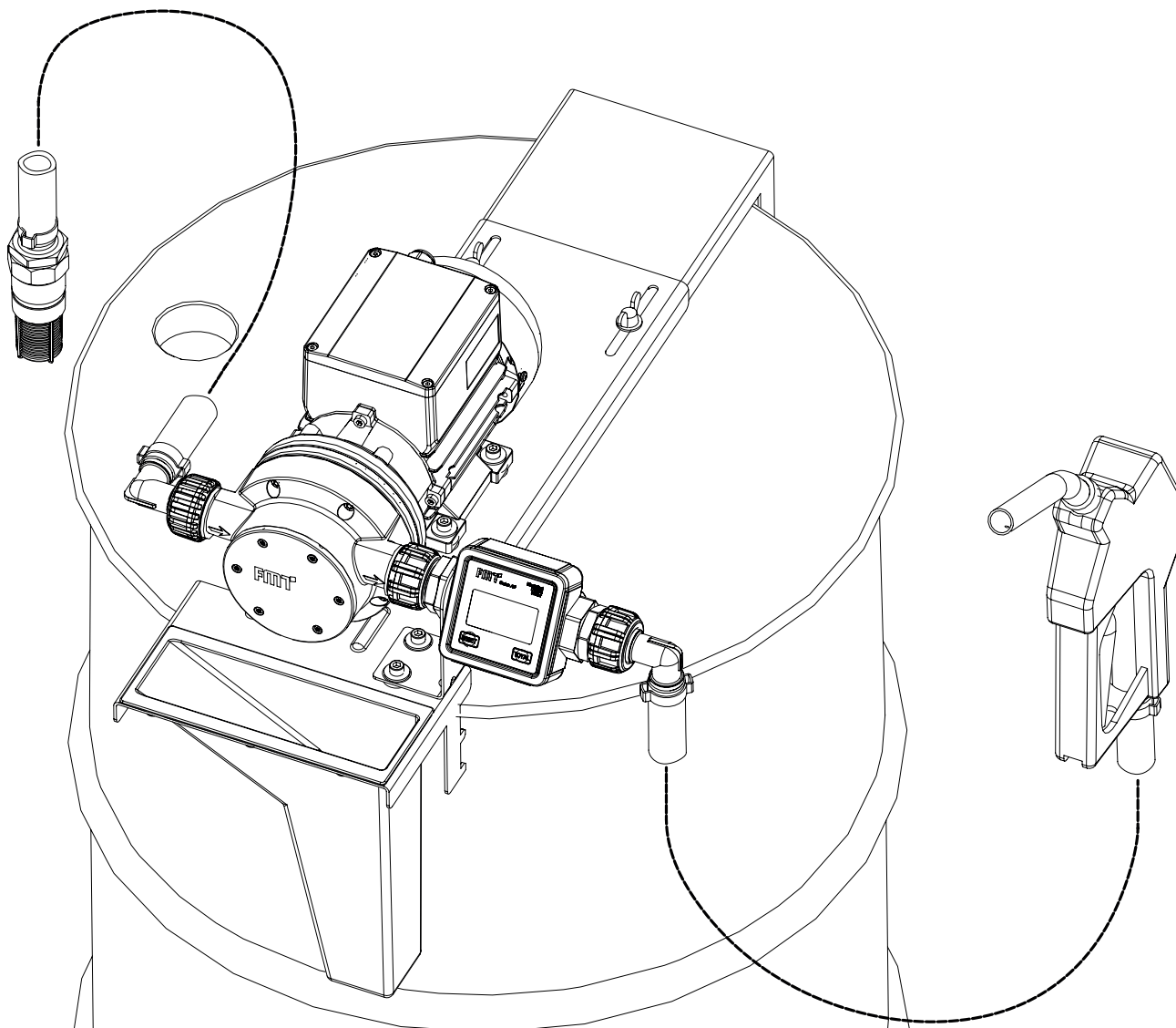

Fig. 19.-2: Assembly on a barrel



CAUTION

- Ensure a stable and safe fastening of the discharge system during each installation.

FMT Swiss AG

Fluid Management Technologies Swiss AG

Gewerbestraße 6

6330 Cham / Schweiz

Tel. +41 41 712 05 37

Fax +41 41 720 26 21

info@fmtag.com

www.fmtag.com