

PIUSI

*Fluid Handling
Innovation*

CUBE
 **B.SMART**

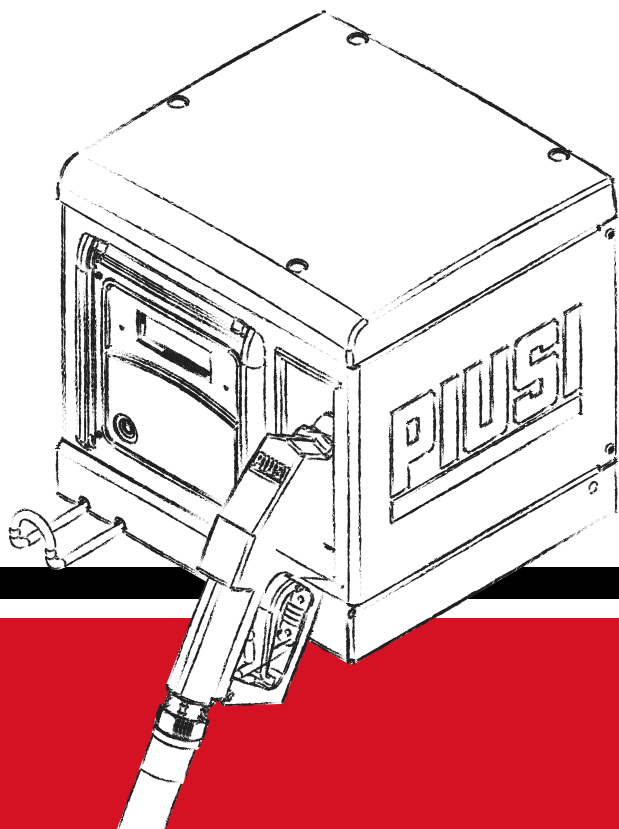

**MADE
IN
ITALY**

Installation, use and maintenance

EN

BULLETIN MO546 EN_03

ENGLISH

BULLETIN MO546

1 CONTENTS

2	CONFORMITY DECLARATION	4
3	GENERAL WARNINGS	4
4	SAFETY INSTRUCTIONS	5
5	FIRST AID REGULATIONS	7
6	SAFETY NORMS	7
7	TRANSPORT, HANDLING AND UNPACKING	8
	7.1 DIMENSIONS AND WEIGHTS	9
	7.2 CONTENT OF THE PACKAGING/PRELIMINARY INSPECTION	10
8	MACHINE AND MANUFACTURER IDENTIFICATION	11
	8.1 POSITION OF THE PLATES	11
9	DESCRIPTION OF THE MAIN PARTS	13
	9.1 CASING AND PUMPING UNIT	13
	9.2 PULSER FLOW METER	13
	9.3 DISPENSING NOZZLE	14
	9.4 LEVEL INDICATOR	14
	9.5 DISPLAY COVER	14
	9.6 DISPENSING MANAGEMENT SYSTEM	14
10	OPERATION	16
11	TECHNICAL SPECIFICATIONS	18
12	USE	20
	12.1 INTENDED USE	20
	12.2 NOT INTENDED USE	20
	12.3 REASONABLY FORESEEABLE MISUSE	20
13	INSTALLATION	21
	13.1 DISPENSER POSITIONING	21
	13.2 STATION FIXING	22
	13.3 HYDRAULIC CONNECTIONS	24
	13.4 ELECTRICAL CONNECTIONS	25
14	INITIAL CONFIGURATION	30
	14.1 SWITCHING-ON	30
	14.2 CONFIGURATION VIA APP AND WEBAPP	31
	14.3 CONTROLLER CONFIGURATION VIA WEBAPP	35
15	START-UP	38
	15.1 FIRST PRIMING	38
16	FLOW METER CALIBRATION	39
17	DAILY USE	39
18	DRIVER ACCESS	40
	18.1 FIRST DRIVER ACCESS FROM APP	40
	18.2 DRIVER - DISPENSING VIA APP	42
	18.3 DISPENSING VIA USER KEY (I-BUTTON)	46
19	MAINTENANCE	48
	19.1 ROUTINE MAINTENANCE	48
	19.2 EXTRAORDINARY MAINTENANCE	50
	19.3 CHECK AND REPLACEMENT OF FUSES	51
20	TROUBLESHOOTING	53
	20.1 MECHANICAL AND HYDRAULIC PROBLEMS	53
	20.2 ELECTRICAL/ELECTRONIC CONNECTIONS	54
	20.3 PROBLEMS WITH THE SMARTPHONE APP	54
21	FAQ	55
22	SCRAPPING AND DISPOSAL	57
23	EXPLODED VIEWS	58

2 CONFORMITY DECLARATION

The undersigned: PIUSI S.p.A.
Via Pacinotti 16/A - Z.I. Rangavino
46029 Suzzara - (MN) - Italy

DECLARES under its own responsibility, that the unit described below:

Description: Dispenser for diesel

Model: CUBE B.SMART

Serial number: refer to the Lot Number indicated on the CE plate affixed to the product
Year of manufacture: refer to the year of production indicated on the CE plate affixed to the product.
conforms to the legal regulations that transpose the following directives:

- Machinery Directive 2006/42/EC
- Electromagnetic Compatibility Directive 2014/30/EU
- ROHS Directive 2011/65/EU
- RED Directive 2014/53/UE

The documentation is at the disposal of the relevant authority upon justified request at PIUSI S.p.A. or request via e-mail: doc_tec@piusi.com The party authorised to compose the technical file and draw up the declaration is Otto Varini in his capacity as legal representative.

Suzzara, 01/09/2020



Otto Varini
legal representative.

3 GENERAL WARNINGS

Important information

For operators' safety and to prevent any damage, the instruction manual must be fully read and understood before carrying out any operation.

Symbols used in the manual

The following symbols will be used in the manual to highlight particularly important instructions, warnings and information.



IMPORTANT

This symbol indicates safety regulations for the operators and/or any persons at risk.



WARNING

This symbol indicates the possibility of damage to the unit and/or its components.



NOTE

This symbol indicates useful information.

Storage of the manual

This manual must be whole and legible in its entirety. The end user and specialist technicians authorised for installation and maintenance must be able to read it at any time.

Reproduction rights

All reproduction rights of this manual are reserved to Piusi S.p.A.
The text cannot be used in other printed publications without written authorisation from Piusi S.p.A.

© Piusi S.p.A.





THIS MANUAL BELONGS TO PIUSI S.p.A.

THE REPRODUCTION OF ALL OR PARTS IS PROHIBITED.

This manual belongs to Piusi S.p.A., the exclusive holder of all rights envisaged by the relevant laws, including by way of example copyright law. All rights according to such law are reserved to Piusi S.p.A.: the reproduction of all or parts of this manual, its publication, alteration, transcription, disclosure to the public, distribution, sale in any form, translation and/or processing, loan, and any other activity reserved by law to Piusi S.p.A.



4 SAFETY INSTRUCTIONS

<p>IMPORTANT Electrical supply - preliminary checks for installation</p>		<p>Completely avoid contact between the electrical supply and the liquid to be pumped.</p>
<p>Inspection and maintenance operations</p>		<p>Before any inspection or maintenance, cut off the POWER SUPPLY</p>
<p>FIRE AND EXPLOSION If there are flammable liquids in the working area, flammable vapours may be present and may cause fire or explosion during station use.</p>	 	<p>To prevent fire and explosion risks: Use the station only in ventilated areas Keep the work area free of scraps, including scraps and solvent or petrol tanks. Do not plug or unplug or operate the switch in the presence of flammable vapours. All devices in the work area must be grounded. Interrupt immediately any action if there are sparks or shocks. Do not use the station until you have identified and resolved the problem. Keep a fire-extinguisher in good working order close to the working area.</p>
<p>ELECTRIC SHOCK</p>		<p>This station must be grounded. Improper installation or use of the station may result in danger of electric shock. Switch off and unplug the power cord after use.</p>
<p>Electrocution or death</p>		<p>Connect only to grounded sockets. Use only grounded cables in accordance with the applicable regulations. Unsuitable extension leads may be dangerous. Make sure that the plug and socket of the extension cords are intact. Unsuitable extension leads may be dangerous. In outdoor use, use only extensions suitable for the specific use, according to the regulations in force. The plug and socket must be connected far from water. Do not expose to rain. Install in a sheltered location. Never touch the plug or the socket with wet hands. Do not turn the distribution system on if the supply connection cable, important parts of the equipment - the suction/delivery tube for example - the nozzle or the safety devices are damaged. Replace the damaged pipe immediately before use. Before each use, check that the mains connection cable and the plug are not damaged. If damaged, have the cable and plug replaced by qualified personnel. The plug and socket must be connected far from water. Outdoors, use only authorised extension leads for which this use is envisaged with an adequate wire diameter in accordance with the regulations in force. As a general rule of electrical safety it is always recommended to power the device by protecting the line with: - circuit breaker/disconnector with a current rating suitable for the power line - 30 mA residual current device The electrical connection must have a ground fault current interrupter (GFCI). Installation operations are carried out with the box open and the electrical contacts accessible. All these operations must be carried out with the unit isolated from the mains in order to avoid hazards of electrocution!</p>

IMPROPER USE OF THE UNIT

Improper use of the device can cause serious damage or death.



Do not operate the unit when tired or under the influence of drugs or alcohol.

Do not leave the work area while the unit is on and operating.

Turn off the unit when not in use.

Do not alter or modify the unit. Alterations or modifications to the unit may invalidate its type-approval and result in dangers to safety.

Arrange the hose and the power cables always far from transit areas, sharp edges, moving parts and hot surfaces.

Do not twist the hose or use a stronger hose.

Keep children and animals far from the work area

Observe all applicable safety regulations.

Do not exceed the maximum working pressure or temperature of the component with the lowest system rating.

See the technical specifications in all machine manuals.

Use liquids and solvents that are compatible with the wet parts of the unit. See the technical specifications in all machine manuals. Read the manufacturer's warnings for liquids and solvents. To obtain more information about the material, request the Safety Data Sheet (MSDS) from your distributor or dealer.

Check the unit every day. Repair or replace worn or damaged parts immediately with original manufacturer's spare parts only.

Make sure that the unit is classified and approved in accordance with the regulations for the environment in which it is used.

Use only the unit for its intended purpose. Contact your distributor for more information.

Keep hoses and cables away from transit areas, edges, moving parts and hot surfaces.

Do not bend or bend the hoses too much or use the hoses to pull the unit.

To avoid severe burns, do not touch liquids or equipment

DANGER OF BURNS



Danger of smoke and toxic fluids.



For problems deriving from the product handled with eyes, skin, inhalation and ingestion, refer to the safety data sheet of the fluid used.

Store treated liquids in suitable containers and in compliance with applicable regulations.

Prolonged contact with the product handled may cause skin irritation; always use protective gloves when dispensing.



FIRE AND EXPLOSION



If it is necessary to dispense in areas classified as hazardous for explosion, it is forbidden to use the smartphone less than 30 cm away from the fluid at the time of dispensing.



The PIUSI B-SMART product has been conceived to be used together with the user's mobile phone only and exclusively for the operations of connection, authentication and connection of the user's device to the fuel dispenser in order to perform remotely certain operations described in this manual.

If the PIUSI B-SMART product is used to refill petrol or other fuel or liquid that emits flammable vapours or in any case creates potentially explosive atmospheres according to the current ATEX regulations (Directive 2014/34/EU and relative applicable national implementing provisions, including any later amendment or additions), the use of the mobile phone while dispensing and in any case within any zone classified for ATEX purposes in accordance with the regulations in force is strictly prohibited, except in the case where the unit is regularly ATEX certified and authorised for use in the relevant area. The mobile phone must therefore remain outside this area or be switched off.

The use of the mobile phone by the user when refilling the vehicle with other non-flammable liquids is in any case strongly discouraged as it can cause distractions that can be dangerous.

PIUSI disclaims any and all liability in the event of damage to the person or property of the user or third parties resulting from failure to comply with the above warnings and / or any other negligent, reckless or imperishable behaviour of the user.

5 FIRST AID REGULATIONS

Persons subjected to electrical discharge

Disconnect the supply, or use a dry insulator for protection when moving the victim far away from any lead. Avoid touching the victim with bare hands until they are far away from any lead. Request the assistance of trained, qualified staff immediately. Never operate switches with wet hands.

NO SMOKING



Do not smoke near the dispenser and do not use the pump near open flames.

6 SAFETY NORMS

Basic characteristics of the protective equipment

- Wear protective equipment that is:
- suitable for the operations to be carried out
 - resistant to the products used for cleaning.

Personal protective equipment to be worn



Safety shoes;



Close-fitting clothing;



Protective gloves;



Safety goggles;

Other equipment



Instruction manual.

7 TRANSPORT, HANDLING AND UNPACKING

CUBE B.SMART is shipped in a cardboard packaging that can be stacked. During storage follow the directions shown on the packaging with graphic patterns about the handling side. If the machine is lifted, check if the capacity of the lifting means and of the accessories (such as the bands) is correct. The use of mechanical means for handling and lifting must be solely entrusted to authorised and suitably trained staff.

During machine inactivity, both packed or unpacked, it should be stored in an area protected against weather agents (rain, moisture, sun, etc...) and dust.

To open the cardboard packaging, use scissors or a cutter, taking care not to damage the system.

With the help of a second operator, fully open the packaging and grasp the CUBE B.SMART putting it vertical, so that it can be positioned afterwards. Once removed from the packaging, the station should always be kept vertical. The packaging elements (cardboard, wood, cellophane, polystyrene, etc...) must be placed in the suitable containers and not left in the environment or within children easy reach as they are potentially harmful. Disposal should be performed in compliance with the standards in force in the utilisation country.

The packaging shall bear the following indications:

- arrow indicating the UPPER side;
- label showing the information for the equipment (model, weight, etc.).

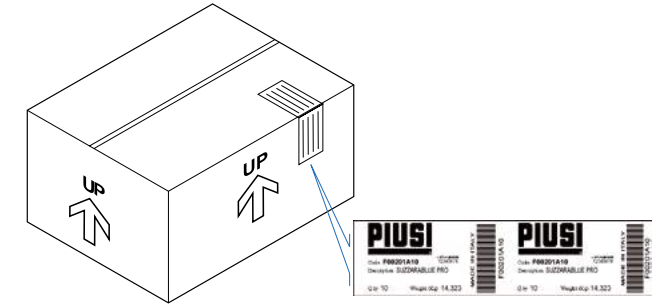



7.1 DIMENSIONS AND WEIGHTS

MODEL	WEIGHT (kg)	PACKAGING DIMENSIONS (mm)
CUBE B.SMART	25	400 x 400 x 460
PEDESTAL KIT	15	-

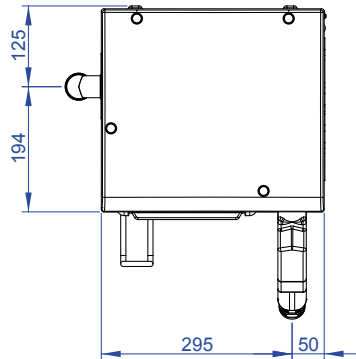
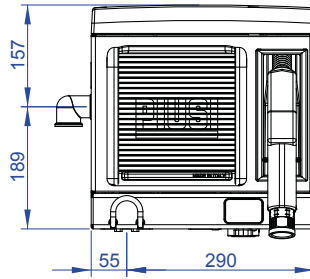
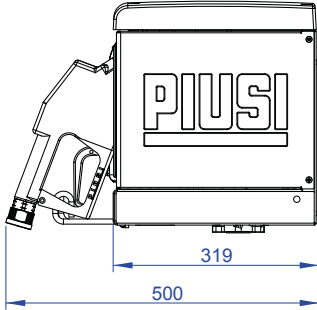

7.2 CONTENT OF THE PACKAGING/PRELIMINARY INSPECTION

Foreword

Before assembly, make sure the machine is integer controlling all parts for possible damage that could hinder safety and functionality.

In case of doubt, do not start up and contact the manufacturer's technical service.

Control if the accessory set is complete.

At the end of the inspection, assemble CUBE B.SMART:

1 INSTALL THE PIPE-HOLDING HOOK



2 INSTALL THE ROCKER OPERATING LEVER



INSTALLATION EXAMPLE

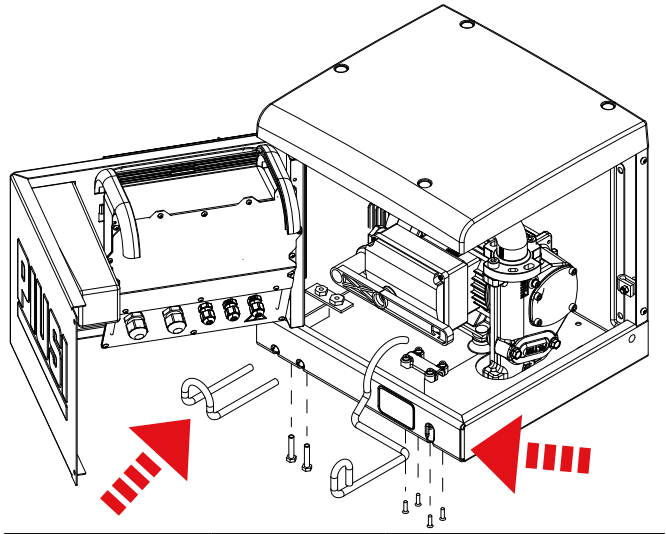

3
APPLY THREAD
SEALANT
TO THE
CONNECTORS
BEFORE FINAL
ASSEMBLY

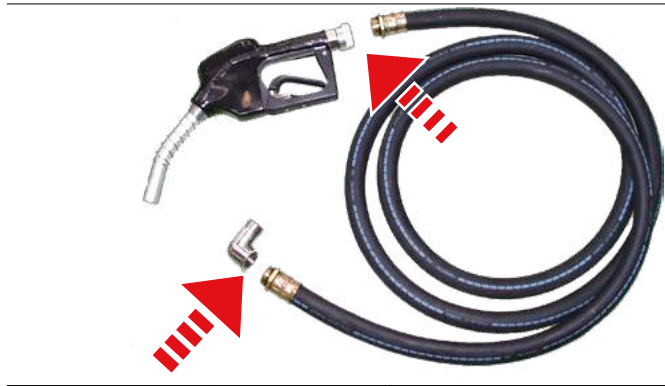

8 MACHINE AND MANUFACTURER IDENTIFICATION

The CUBE B.SMART stations are equipped with an identification plate attached to the frame:

- Model
- Serial number / year of manufacture
- Technical data
- CE marking
- Manual code

IMPORTANT



Before installation, always check that the dispensing system model is correct and suitable for the supply currently available (Voltage / Frequency).

8.1 POSITION OF THE PLATES

Some stickers and/or plates are applied to the distribution system to indicate the most relevant information to the operator. It is necessary to check that these do not deteriorate or detach over time.

NOTE



Should this occur, please contact our customer assistance office so that we can send you copies of the spoilt or missing plates/labels for reapplication where originally provided.

The following labels are present:



1

- Pump operation plate.

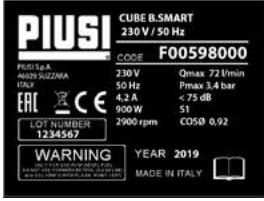

2 - CE plate with technical data



3 - Attention plate applied to the CUBE display



4 - Corner label plate applied on the box



5 - Product warranty label

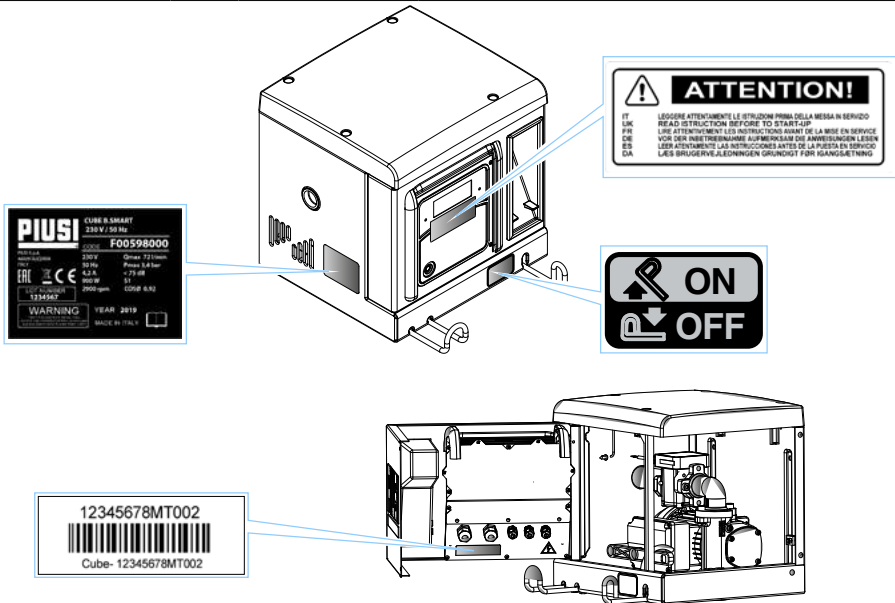

9 DESCRIPTION OF THE MAIN PARTS



9.1 CASING AND PUMPING UNIT

The CUBE B.SMART dispenser are designed for the transfer of diesel fuel for non-commercial use. Featuring maximum safety and ease of use, CUBE dispensers are reliable, high-performance equipment; they are installed quickly and are ready for use. Equipment and characteristics:

- 1 Self-priming rotary vane pump with built-in by-pass valve.
- 2 Motor with IP55 protection degree and thermal protection, 230 V AC single phase.
- 3 Four metres of antistatic rubber hose for fuels.
- 4 Automatic dispensing nozzle with ON/OFF switch integrated in the nozzle support.
- 5 Steel casing with anti-corrosion treatment and finishing paint.
- 6 Dispensing system
- 7 Flow meter

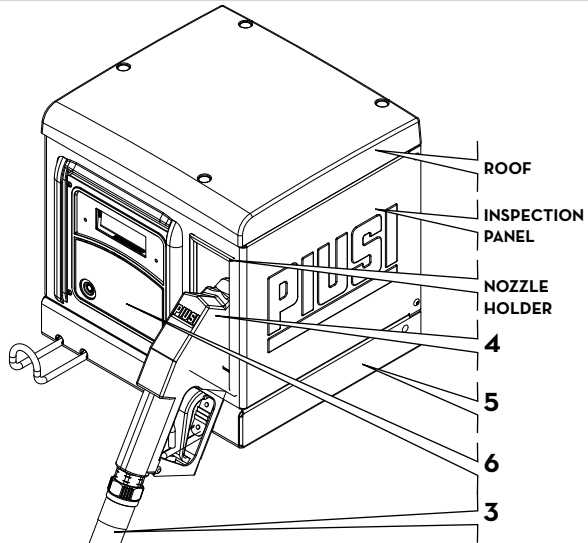

Unit with self-priming vane electric pump, equipped with by-pass valve. This valve allows operation for short periods even with the dispensing nozzle closed. The motor, directly coupled to the pump body, is asynchronous, closed type (IP55 protection class according to the EN 60034-5-86 norm), self-ventilated, single-phase. For more information, refer to the individual component manuals.

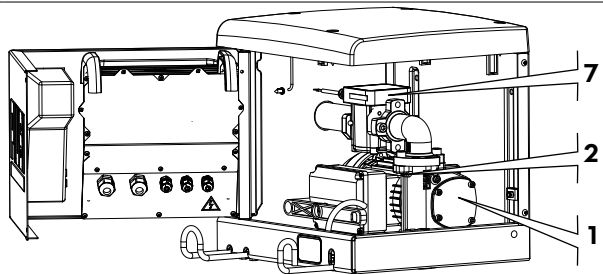

9.2 PULSER FLOW METER

The Pulser K600/3 flow meter has a high-precision oval gear measuring system designed to allow accurate fuel measurement. They consist of a sturdy die-cast aluminium structure, complete with inlet filter and are easy to maintain and reliable. For further information, please refer to the dedicated manual.

9.3 DISPENSING NOZZLE

The dispensing nozzle supplied with CUBE B.SMART is an automatic type, with a stop device when the tank is full.

9.4 LEVEL INDICATOR

The level indicators to which the dispenser can be connected are only clean contacts, which are configured by WebApp.

9.5 DISPLAY COVER

To ensure adequate protection for the panel, a damper display cover has been designed which can be lowered if necessary. It is advisable, in very strong sunlight conditions, to keep the display cover always lowered.

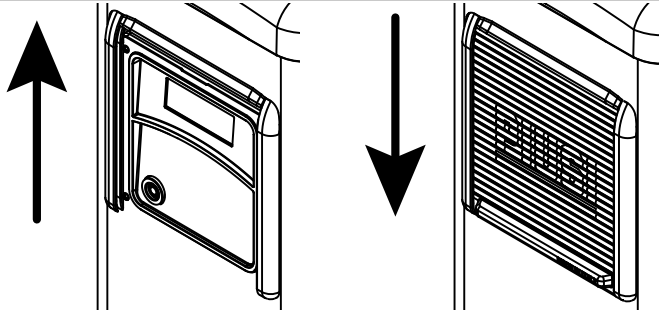

9.6 DISPENSING MANAGEMENT SYSTEM

FOREWORD

B.SMART is an electronic system for controlling the dispensing of fluids via smartphone.

The control system consists of:

An electronic controller

equipped with a BlueTooth interface (BLE 4.0 and later), a display and an interface LED that controls a dispensing pump

An APP

installed on a smartphone equipped with an Android operating system or Apple iOS

A WebAPP

namely an internet portal accessible from any PC or Tablet connected to the internet from which the entire site can be monitored

SYSTEM FUNCTIONS

- site configuration, acquisition and management of refillings, management of refilling fuel dispensers, management of drivers, vehicles and detailed reporting of the dispensings via WebAPP accessible from any PC/Tablet, using your credentials
- Fuel dispensing using the dedicated APP: PIUSI APP, downloadable only for smartphones from Play Store and App Store, which connects to the fuel dispenser / controller via BLE connection
- Fuel dispensing using the dedicated APP also in areas without 3/4G coverage and Wi-Fi
- Dispensing via iButton associated with the individual driver
- Possibility to remotely manage sites far from the company headquarters

As can be seen from the descriptive diagram on page 15, an example of a basic system structure is given showing the possibility of managing multiple controllers simultaneously, within the same plant

For more specific details on modes of connection and communication between controllers, please refer to the manual found in the system management WebApp.

COMPATIBILITY WITH OPERATING SYSTEMS

The system is compatible with the following iOS versions:

- iOS10
- iOS11
- iOS12 and subsequent

The system is compatible with the following Android versions:

- 4.4
- 5.0 - 5.1
- 6.0
- 7.0 - 7.1
- 8.0
- 9.0 and subsequent

DISPENSER

Composed of an electronic controller to manage fuel dispensing, equipped with:

- Numeric display
- Reader for iButton
- BLE 4.0 connection (or following)
- Status sensors for: level alarms, flow meters, positioning of the dispensing nozzle
- Pump on/off control

CLOUD

Where there is the database to store the configurations of the site and the dispenser, the drivers, the license plates of the vehicles and all the dispensings

WebApp

Web interface used by the site manager. It has various functions: it monitors the dispensings (from whom they were made, when, in which fuel dispenser), creates/eliminates users from the site, adds/removes fuel dispensers from the site. The only external device the WebApp connects to is a USB reader for iButton

APP

It makes several operations:

- It manages two types of users: driver and manager
- It sends commands to the fuel dispenser and receive answers, the commands are used to perform: dispensing, calibration, updating the firmware of the fuel dispenser, downloading updates of the fuel dispenser configuration, managing the drivers or loading in the cloud the dispensings in the fuel dispenser

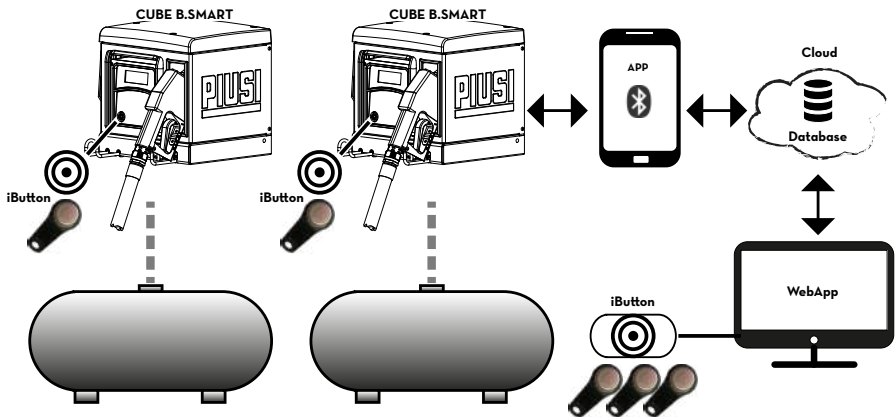

10 OPERATION

The fuel dispenser is powered by a voltage ranging from 220 V to 240 V, 50 Hz. It is equipped with a motor, 4-character backlit display, iButton reader, blue LED for Bluetooth connection and red LED for warning/alarm:

If the display back lighting is active, this means that the driver or manager has been authenticated via smartphone or the driver has been authenticated via iButton.
The display shows: the version of the installed firmware, the dispensing value, the time, the warning or alarm code when the red LED is on, the boot status for the firmware update and the percentage of firmware transferred

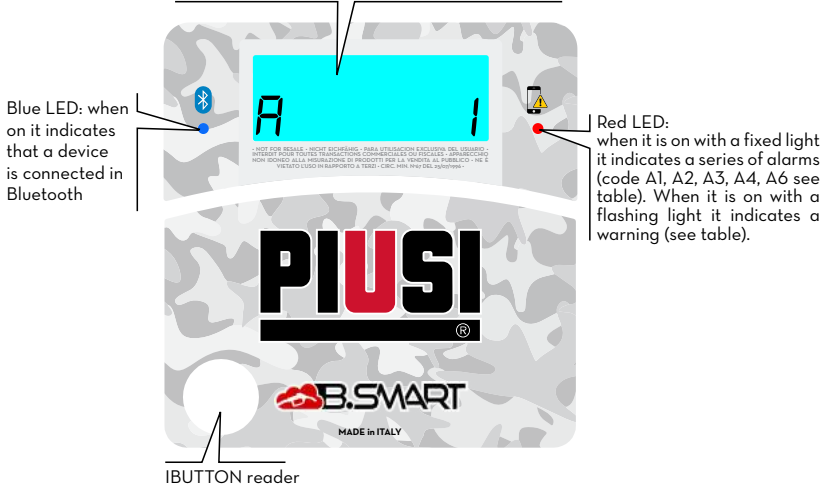

NOTE



Red LED on - It switches on due to several factors, each time the LED lights up the display shows a code indicated by a letter A and by an incremental number. Whenever the led is on, it is not possible to dispense.

Below are the possible coded errors, with their respective resolution methods:

Coding	Description	Explanation/Solution
[1	WARNING_MASTER_PUMP_GROUPA_LEVEL1_CONTACT	Contact 1 associated with pump A of the main controller is active: red LED flashing.
[2	WARNING_MASTER_PUMP_GROUPA_LEVEL2_CONTACT	Contact 2 associated with pump A of the main controller is active: red LED flashing.
[3	WARNING_MASTER_PUMP_GROUPA_THR1	The tank associated with pump A of the main controller has reached the level 1 threshold: red LED flashing.
[4	WARNING_MASTER_PUMP_GROUPA_THR2	The tank associated with pump A of the main controller has reached the level 2 threshold: red LED flashing.
[9	WARNING_SLAVE_PUMP_GROUPA_LEVEL1_CONTACT	Contact 1 associated with pump A of the secondary controller is active: red LED flashing.
[10	WARNING_SLAVE_PUMP_GROUPA_LEVEL2_CONTACT	Contact 2 associated with pump A of the secondary controller is active: red LED flashing.
[11	WARNING_SLAVE_PUMP_GROUPA_THR1	The tank associated with pump A of the main controller has reached the level 1 threshold: red LED flashing.
[12	WARNING_SLAVE_PUMP_GROUPA_THR2	The tank associated with pump A of the secondary controller has reached the level 2 threshold: red LED flashing.

C 17	WARNING_MASTER_PUMP_GROUPA_PROBE_OCIO	Fault detected on the level sensors connection line. (The system allows manual dispensing)
C 19	WARNING_MASTER_SLAVE_GROUPA_PROBE_OCIO	Fault detected on the level sensors connection line. (The system allows manual dispensing)
C 25	WARNING_CANBUS_COM	Fault detected on the connection line between controllers. The system behaves as for probe alarms, allowing manual dispensing
A 1	ALARM_MASTER_PUMP_GROUPA_LEVEL1_CONTACT	Contact 1 associated with pump A of the main controller is active: red LED on (not flashing). Delivery not possible
A 2	ALARM_MASTER_PUMP_GROUPA_LEVEL2_CONTACT	Contact 2 associated with pump A of the main controller is active: red LED on (not flashing). Delivery not possible
A 3	ALARM_MASTER_PUMP_GROUPA_THR1	The tank associated with pump A of the main controller has reached the level 1 threshold: red LED on (not flashing). Delivery not possible
A 4	ALARM_MASTER_PUMP_GROUPA_THR2	The tank associated with pump A of the main controller has reached the level 2 threshold: red LED on (not flashing). Delivery not possible
A 9	ALARM_SLAVE_PUMP_GROUPA_LEVEL1_CONTACT	Contact 1 associated with pump A of the secondary controller is active: red LED on (not flashing). Delivery not possible
A 10	ALARM_SLAVE_PUMP_GROUPA_LEVEL2_CONTACT	Contact 2 associated with pump A of the secondary controller is active: red LED on (not flashing). Delivery not possible
A 11	ALARM_SLAVE_PUMP_GROUPA_LEVEL1_THR1	The tank associated with pump A of the main controller has reached the level 1 threshold: red LED on (not flashing). Delivery not possible
A 12	ALARM_SLAVE_PUMP_GROUPA_LEVEL1_THR2	The tank associated with pump A of the secondary controller has reached the level 2 threshold: red LED on (not flashing). Delivery not possible
A 28	ALARM_BUFFER_FULL	The dispensing buffer is full. All the dispensing operations stored in the controller must be uploaded to the cloud
A 29	ALARM_INACTIVE_PUMP	No pumps are active (Check system configuration on WebApp)
A 30	ALARM_RTC_RESET	The time has been lost. The current time must be uploaded to the controller via a smartphone
A 31	ALARM_RTC_FAULT	Time synchronization not possible (Contact the Service Department).
A 32	ALARM_SOFT_MEMORY_DATA_FAULT(Cumulative)	Corrupted memory (data can be reset from WebApp backup)
A 33	ALARM_HARD_MEMORY_DATA_FAULT(Cumulative)	Corrupted memory (data can be reset from WebApp backup)
A 34	ALARM_VERY_HARD_MEMORY_DATA_FAULT(Cumulative)	Damaged memory (contact the Service Department)

With regard to the warning/alarm logics, it should be noted that one or more controllers can be connected to the same tank, or share common level contacts as outlined in the paragraph describing the system.

In these situations, warnings and alarms from one controller will be propagated to the other controllers sharing the same resource.

For more specific details on modes of connection and communication between controllers, please refer to the manual found in the system management WebApp.

11 TECHNICAL SPECIFICATIONS

INTENDED USE

Implementation of a system for the dispensing and control of fluids for private use not subject to special regulations such as ATEX for potentially explosive environments.

IMPORTANT



DO NOT INSTALL CUBE B.SMART IN ENVIRONMENTS CLASSIFIED AS POTENTIALLY EXPLOSIVE IN ACCORDANCE WITH ATEX REGULATIONS.

MAXIMUM VARIATIONS IN ELECTRICAL PARAMETERS IMPORTANT

The Motors in the fuel dispensers accept maximum variations: of supply voltage of +/- 5% and maximum variations of frequency of +/- 2% SEE TECHNICAL SPECIFICATIONS TABLE BELOW



BEFORE INSTALLATION, ALWAYS CHECK THAT YOUR MODEL IS CORRECT AND SUITABLE FOR THE SUPPLY EFFECTIVELY AVAILABLE (VOLTAGE / FREQUENCY).

Signal	Standard conditions	Limits	Notes
Power supply input	220 V ac - 240 V ac for 230 V ac and 50 Hz	900 W - 4.2 A	The electronic board is equipped with a switching technology power supply that allows a wide range of voltages and frequencies and therefore makes the equipment robust for the high fluctuations of voltage or frequency present on the power distribution mains in many areas of the world
Electronic Key Interface	YELLOW key (iButton): Enabling input by PIUSI electronic key	Through a software procedure, the yellow keys of the drivers are registered on the PC and then these drivers are enabled on one or more dispensing stations	You can configure whether or not such a key is present
Level 1 contact input (only for versions where available)	Clean contact or Open Collector (NPN) electronic signal If it is necessary to supply a level sensor, 24 V dc are also available on the terminal. The maximum current available to the sensor for its power supply is 25 mA	About 1 mA at 5 V dc will be supplied on the clean contact (or on the open collector)	It is possible to configure whether or not this signal is present, and it is also possible to configure the type of signal (normally open or normally closed for versions where provided) Finally, it is possible to choose the action to be taken by the controller when it receives this signal: it can only give an alarm on the display or it can totally inhibit other dispensings if the Pump Block is set
Level 2 contact input (only for versions where available)	Clean contact or Open Collector (NPN) electronic signal If it is necessary to supply a level sensor, 24 V dc are also available on the terminal. The maximum current available to the sensor for its power supply is 25 mA	About 1 mA at 5 V dc will be supplied on the clean contact (or on the open collector)	It is possible to configure whether or not this signal is present, and it is also possible to configure the type of signal (normally open or normally closed for versions where provided) Finally, it is possible to choose the action to be taken by the controller when it receives this signal: it can only give an alarm on the display or it can totally inhibit other dispensings if the Pump Block is set

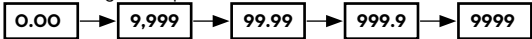
24 V dc auxiliary power supply output	24 V dc auxiliary output to supply external electronic devices	I _{max} = 25 mA	The device to be supplied must not absorb more than 25 mA with 24 V dc power supply. Typically it could be a level sensor
Fuses	F1 (V ac power input) 800 mA T (delayed) F2 (motor output) 20 A T (delayed) F3 (AC/DC output) 800 mA T (delayed)		
IP protection degree	IP 55		
Operating temperature	From -10°C to +40°C		
Storage temperature	From -20°C to +60°C		
Humidity	< 90%		
Wiring distances	Max. pulser distance	15 m	
	Max. level sensor distance	100 m	
Displaying and Metering limits	<p>The floating point sequence: 0.00 -> 99.99 -> 999.9 -> 9999</p> <p>The maximum quantity that can be dispensed is 9999 units regardless of the unit of measurement set litres/gallons/pints</p> <div style="text-align: center;">  <pre> graph LR A[0.00] --> B[9,999] B --> C[99.99] C --> D[999.9] D --> E[9999] </pre> </div> <p>PRESET: Presetable 9999 litres/gallons/ maximum quantity pints</p>		
Memories	<p>The electronic controller can store:</p> <ul style="list-style-type: none"> - Up to 500 drivers - Up to 500 dispensings 		

12 USE

12.1 INTENDED USE

IMPORTANT
Environmental
use conditions



THE B.SMART CUBE DISPENSER HAS BEEN DESIGNED AS A DIESEL REFILLING STATION FOR NON-COMMERCIAL USE. DEDICATED APP AND WEB APP MAKE IT EASY TO USE, BY RETURNING A SUMMARY OF ALL DISPENSINGS.

Ambient temperature: min. -20°C / max. +40°C

Relative humidity: max. 90%

The limit temperatures indicated apply to the pump components and must be observed to avoid possible damage or malfunction.

12.2 NOT INTENDED USE

IMPORTANT
Flammable
liquids and
explosive
atmospheres



CUBE B.SMART HAS NOT BEEN DESIGNED IN ACCORDANCE WITH ATEX REGULATIONS OR TO OPERATE IN ENVIRONMENTS WITH A POTENTIALLY EXPLOSIVE ATMOSPHERE.

DO NOT INSTALL CUBE B.SMART IN POTENTIALLY EXPLOSIVE LOCATIONS.

The system was not designed for the dispensing of diesel, petrol, flammable liquids with flash point <55°C/131°F, or for operation in environments with a potentially explosive atmosphere.

Use in the conditions indicated above is therefore prohibited.

IMPORTANT
Use not
envisaged



Use of the system for purposes other than those intended is strictly prohibited. Any use other than that for which the system was designed and described in this manual is considered "IMPROPER USE", for which Piusi S.p.A. accepts no responsibility in case of damage to property, persons, animals or the system itself.

12.3 REASONABLY FORESEEABLE MISUSE

The smartphone is an indispensable tool for CUBE B.SMART to set up and record the dispensings managed by the system, but it is forbidden to use it when dispensing near the dispenser.

IMPORTANT



Use your smartphone only and exclusively to connect, authenticate and pair from your device to the dispenser. When refilling the vehicle, even with non-flammable liquids, the use of the telephone is in any case strongly discouraged as it can cause distractions that can be dangerous.

13 INSTALLATION

FOREWORD

CUBE B.SMART can be installed outdoors. However, it is advisable to shelter it under a canopy to ensure a longer life and provide more comfort when refilling in bad weather. The installation of the dispenser must be carried out by specialised personnel and carried out according to the instructions provided in this chapter. If CUBE B.SMART is not sheltered under a canopy, a “display cover” is provided as protection for the display and keypad.

WARNING Staff authorised for installation



All installation operations must be performed only by competent and authorised staff, who must:

Install the system in a dry, well-ventilated place;

Properly install the accessories necessary for the correct operation of the equipment.

Use solely the accessories provided with the system.

IMPORTANT



The use of unsuitable accessories not provided with the system is strictly prohibited. Piusi S.p.A. accepts no responsibility for harm to persons, property or the environment due to failure to observe this instruction. THE UNIT IS FOR PROFESSIONAL USE ONLY.

The unit must be installed in an adequately lit location, in compliance with the regulations in force.

The unit has been designed to be used in a dry place. If it is installed outdoors, provide adequate protective covering.

The motors are not explosion-proof. Do NOT install in places with explosion hazard.

13.1 DISPENSER POSITIONING

The positioning of CUBE B.SMART must ensure that:

- Removable panels can be easily removed for access to internal components when necessary.

- The maximum distances and differences in level between the station and the tank are respected

- A correct and solid fixing of the casing to the ground on a horizontal plane is possible.

The positioning of the station determines the following parameters, which characterize each installation:

Hp: Priming height

Ls: Total length of the suction pipes - from the bottom valve to the station (in metres).

The following restrictions must be observed for the stations to function properly:

Hp max: no more than 3 metres

Ls max: no more than 15 metres

13.2 STATION FIXING

Before starting installation, check that any packaging materials have not been trapped in the pipes. Prepare suitable support clamps or fixing brackets according to the position in which you want to fix CUBE B.SMART. The pipe coming from the tank must be aligned with the threaded inlet of the pump filter, located under CUBE B.SMART.

TANK ABOVE GROUND

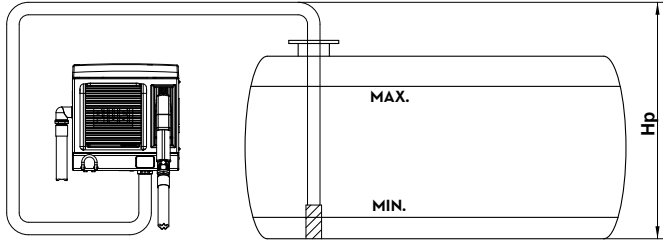

TANK UNDERGROUND

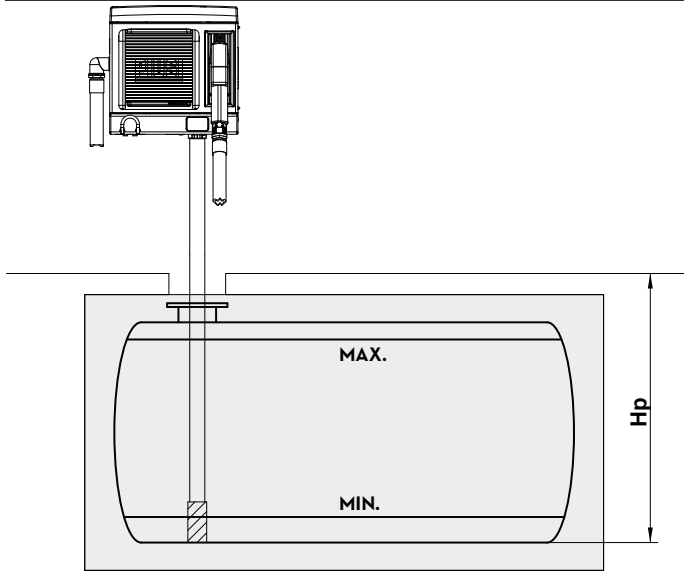

CUBE B-SMART can be installed on the wall or on a pedestal. For wall mounting, it will be necessary to have a nr. 4 M8 screws. For pedestal mounting, use no. 4 M6 screws. Below are the diagrams with the center distances of the holes for a precise installation. The pedestal is a Piusi accessory not included in the CUBE B-SMART supply.

WALL FIXING

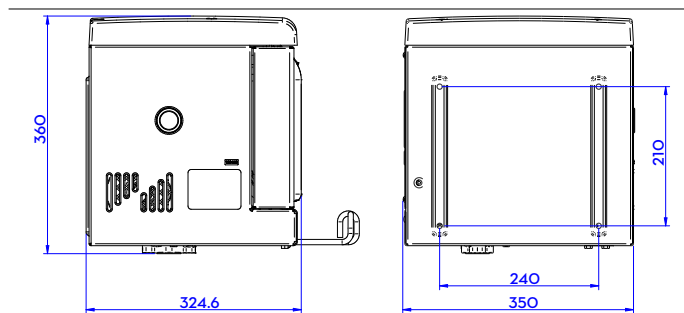

**FIXING UP
PEDESTAL**

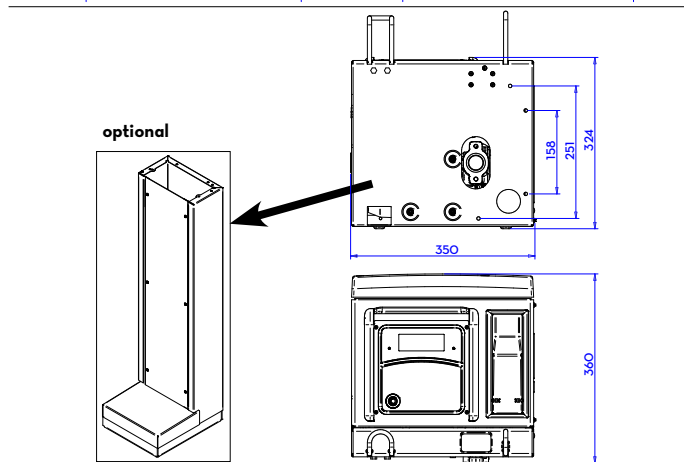

EN

13.3 HYDRAULIC CONNECTIONS

Always observe the following WARNINGS:

- Use pipes and joints suitable for use under vacuum
- Use pipes and accessories suitable for use with the handled liquid. Materials not suitable for such use may cause serious damage to the pump and may also cause pollution.
- Do not use joints with conical threads that may damage the threaded port of the pump filter if forced beyond what is necessary.
- Use wide radius bends to minimize pressure drop.
- Make sure that the suction line is perfectly clean and free from waste.
- Always install a bottom valve with filter at the end of the suction pipe. The valve must be placed on the bottom of the tank and have the same diameter as the pipe.
- Before starting installation, check that any packaging materials have not been trapped in the pipes.

SUCTION LINE

The diameter of the suction line “Ds” must be selected according to the station model and positioning in relation to the tank. With reference to the values of “Hp” and “Ls” defined in point 12.1, the following **MINIMUM DIAMETERS** of the suction pipe must be strictly observed.

MAXIMUM LENGTH OF THE SUCTION PIPES

The maximum length of the pipe, the diameter of the pipe, the height difference “Ho” are closely related parameters to form the suction condition. The latter must not be such as to create a vacuum greater than 0.6 bar. Therefore, after having respected the minimum diameter for the pipe, specified in the “Recommendations and Warnings” below, the length of the pipe is the smaller, the greater the height difference Ho that the diesel must overcome and vice versa: indeed, the vacuum increases progressively by 0.08 bar for each meter of increase in the static height of the pump compared to the flush level of the diesel in the tank.

RECOMMENDATIONS AND WARNINGS



- The suction pipe must withstand a pressure of at least 10 bar and must have a minimum diameter NOT LESS than 1”1/4
- The pipe must also be suitable for vacuum operation.
- Use pipes and accessories suitable for use with diesel. Materials not suitable for use with diesel can damage the pump or hurt people, as well as cause pollution.
- Any bends in the suction line must have the widest possible radius in order to minimise pressure drop.
- Make sure that the suction line is clean and free from waste.



13.4 ELECTRICAL CONNECTIONS

ELECTRICAL CONNECTIONS

The electrical connections must be carried out in a workmanlike manner by specialised personnel, in full compliance with the regulations in force in the country of installation and with the instructions in the electrical diagrams in this manual.

IMPORTANT



The CUBE B.SMART Electronic Panel is NOT equipped with circuit breakers; it is therefore essential to install upstream CUBE B.SMART an electrical power supply panel equipped with a circuit breaker / disconnector with a current rating suitable for the electrical line and a differential switch suitable for the type of electrical load.

Otherwise, provide for a quick disconnection system such as a socket/plug connection to be used in the event of faults.

IMPORTANT



Before accessing the electrical parts, make sure that you have disconnected all the main switches that energize the unit.

The operations required for a correct wiring are described below:

- Opening CUBE
- Opening the rear cover of the controller
- Closing the rear cover of the controller
- Closing CUBE

**OPENING CUBE
OPENING THE REAR COVER OF THE CONTROLLER**

Loosen all 7 screws of the rear cover of the controller to access the compartment of the electronic boards

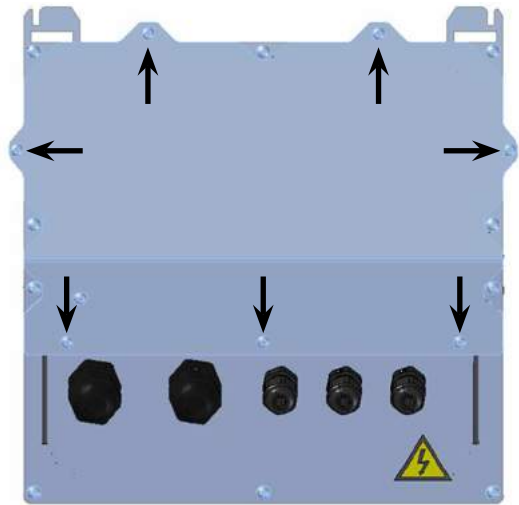

CABLE GLAND CONNECTION

Cable gland connection: the cable glands to be used for the various signals are indicated in order to obtain an optimised cable route inside the controller Pulser input and motor output are already wired.

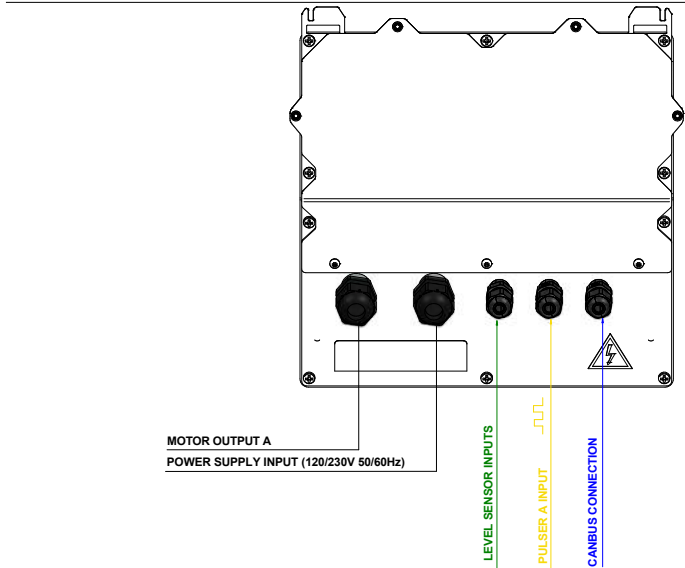

Once the cover has been opened, the electronic board and its connectors are accessed:

POWER SUPPLY CONNECTOR
 Power supply INPUT 100/240 Vac depending on motor models - 50/60 Hz. The line must be disconnected by an electrical panel or a plug-socket assembly.

SIGNALS CONNECTOR
 Connector for: level 1 and 2 contact, pulser input, GND and 24 Vdc and 25 mA power supply output

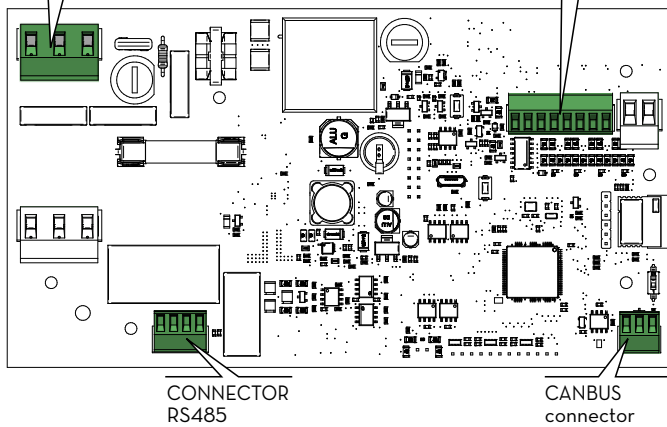



IN DETAIL:

1
Power supply
cable:
Voltage values:

Insert the grounding wire (yellow/green sheath) into the central hole of the terminal, then phase and neutral respectively on the right and left and tighten the wire fixing screws.

The electronic controller must be supplied with voltages and frequencies compatible with the motor to be driven:

If the motor is 230 V ac at 50 Hz, the controller must be supplied at the same voltage and frequency (220 V ac - 240 V ac at 50 Hz)

IMPORTANT



the CABLE CROSS-SECTION must be chosen according to the electrical current absorbed by the motor, which is the device in which almost all the current flows.

Pay attention to the cable specifications:

- The signal cables and power cables used in this product must have an insulation rating of 300V or more.
- The power cable must have a section of AWG 16 or more

NOTE



The maximum current absorbed by the 230 V motor is 4.2 A

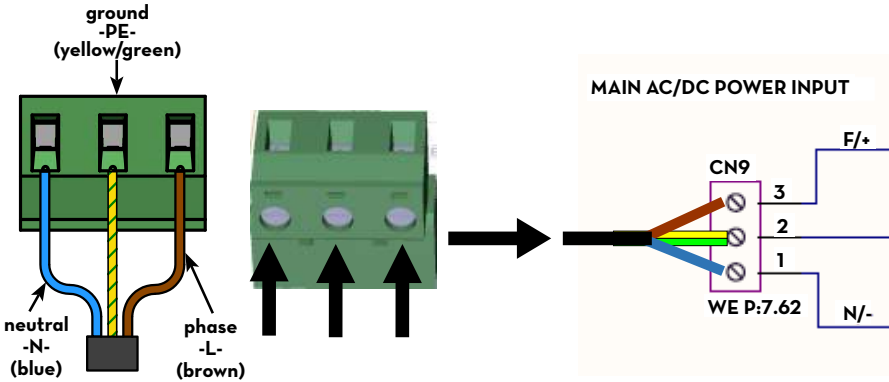

2
SIGNALS
connector:
3
LEVEL
CONTACTS
ELECTRICAL
CONNECTION

Output 24 V dc and 25 mA, pulser, level 1 and 2 contact.
 Tighten the screws on the top of the 8-hole terminal for: level 1 contact, level 2 contact

With reference to the level 1 contact and level 2 contact, it is necessary to underline that these are configurable contacts which can be used to connect:

- level sensor 4-20mA
- level sensor 0-10V
- Clean contact (switch not necessarily connected to the level sensors inside the tank)

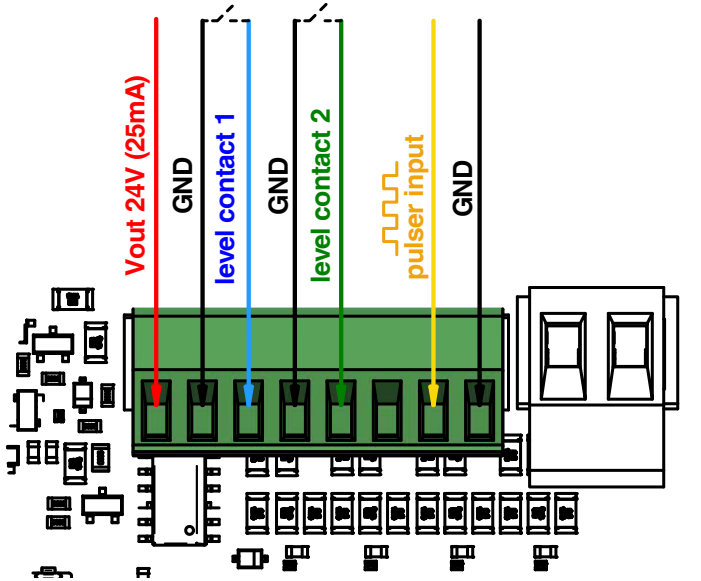

4
Serial
connection:
NOTE



The B.Smart board has two RS485 serial communication channels. As well as the level contacts on the signals terminal board, it is possible to connect the OCIO detection system to the B.Smart board.

When using OCIO 2.0 on the RS485 connector, DO NOT connect the level contacts 1 and 2 on the signals connector.

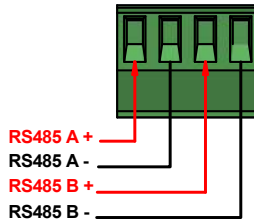

5
CANBUS
connection:

The controllers can be connected to each other, via CANBUS connection. The figure shows the connector on each individual board and a small diagram showing the connection between x number of controllers.

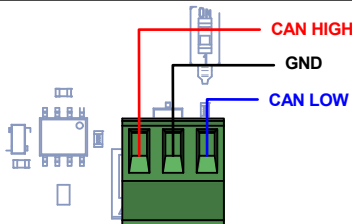

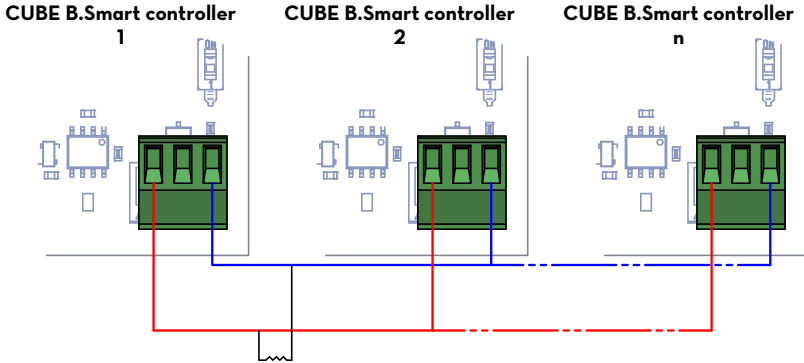

Insert the 120 ohm resistor provided between CAN HIGH - CAN LOW and connect the resistor output wires to the terminal boards, as shown in the figure.

CAUTION



The 120 ohm resistor must be inserted in the CANBUS line ONCE ONLY, as shown in the connection diagram.

NOTE



For the CANBUS connection, it is recommended to:

- Use a cable with a characteristic impedance of 120 ohms
- The length of the connection between the various CUBE B.SMARTs must not exceed 100 m.

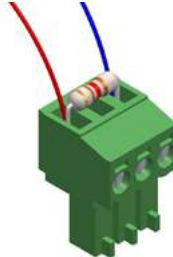

- 6 Closing the rear cover of the controller
- 7 Closing CUBE

Replace the cover and tighten the 7 screws

Tighten the 2 side screws

14 INITIAL CONFIGURATION

Before use, you must set up your system by connecting your CUBE B-SMART to the Smartphone App and the dedicated WebApp. This section explains all the steps required for a correct configuration.

To configure the system you need to:

- Switch the dispenser on;
- Configure the dispenser via APP;
- Configure the dispenser via WebApp

14.1 SWITCHING-ON



The following is the sequence of messages given by the system during the switching-on phase

1		<p>Display, BLUE and RED LEDs light up</p>
2		<p>All segments ON</p>
		<p>All segments OFF</p>
3		<p>The first part of the firmware revision index is shown (in this example r.1.00)</p>
4		<p>The last part of the firmware revision index (i = internal) is shown: i.00</p>
5		<p>The backlighting of the display and the LEDs turn off and 0.00 appears on the display</p>

14.2 CONFIGURATION VIA APP AND WEBAPP

FOREWORD

Initially it is necessary to assign the purchased SYSTEM CODE to the controller.
To do this, your smartphone must be connected to the 3/4G or Wi-Fi network, so check the status at the bottom left of the screen:

 OFFLINE	OFFLINE: APP/smartphone not connected to 3/4G or Wi-Fi
 ONLINE	ONLINE: APP/ smartphone connected to 3/4G or Wi-Fi

- From your smartphone, go to the Play Store or App Store and search for PIUSI APP. 
- The icon is: . Download and install the application.
Activate your smartphone's Bluetooth and GPS and open the APP.
Then follow the steps described below:

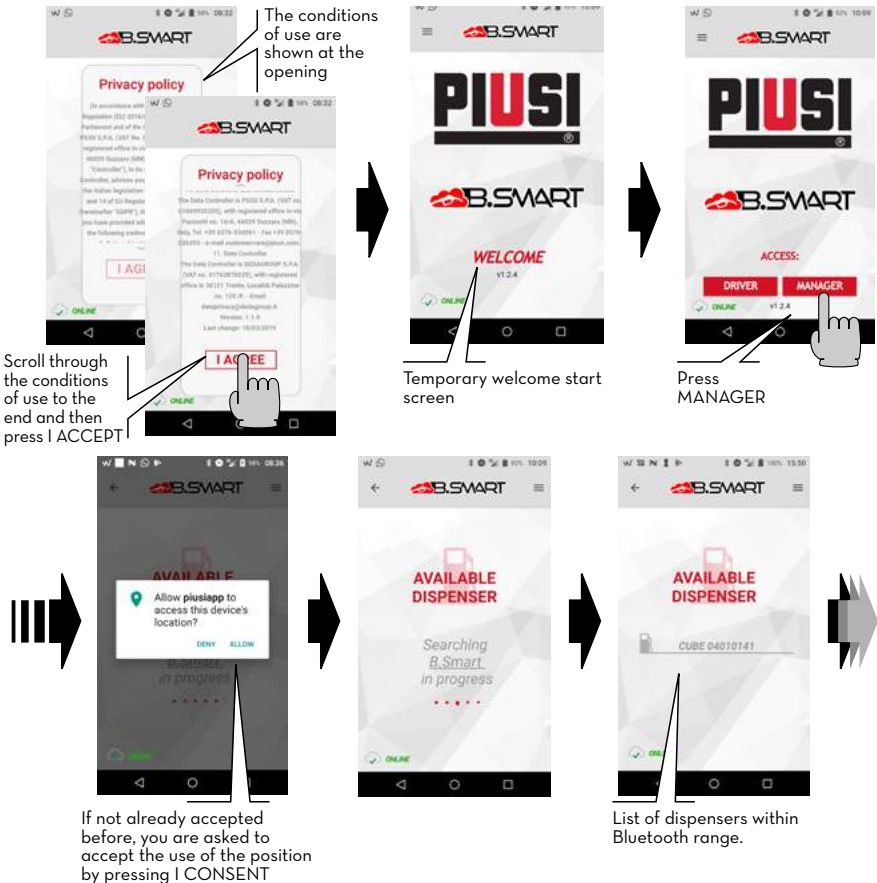

DURING THE SEARCH, THE FOLLOWING ERRORS MAY OCCUR



DISPENSER SEARCH IN PROGRESS...



DISPENSER FOUND



BLUETOOTH DEACTIVATED
activate Bluetooth from your smartphone settings

Activate the GPS, using the button in the upper right and choose the type of service, from those in the list

Press **I ACCEPT**, to accept the consent to the position, then return to the APP, which will show the list of fuel dispensers



GPS DEACTIVATED
If GPS is deactivated, press **ACTIVATE** to open the settings screen





THE PIN MUST BE ENTERED

The manager PIN to be entered at the first installation is **123456** press **CONFIRM** to continue

Wait for authentication to finish

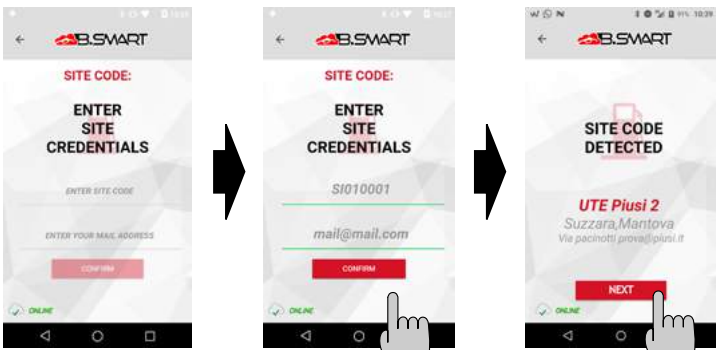

Entering of the **SYSTEM CODE (site CODE)** and the **EMAIL** address of the portal user who activated the site is required

IMPORTANT: SEE REGISTRATION GUIDE (MO548)

Enter the **SYSTEM CODE** acquired in the license and the **EMAIL** address of the portal user who registered the pump on the PIUSI portal. In this example it is: **Ute00004**

SITE CODE detected. Press **CONTINUE**. The system data appears on the screen.



The dispenser is uploaded in the cloud



Other operations by the manager are shown (in addition to the discovery and registration in the cloud)
The operations are:
1 - Meter calibration
2 - Forced synchronization of data in addition to all automatic synchronizations
3 - Firmware updates of the electronic controller
Press HOME to return to the APP HOME



HOME page of the APP

14.3 CONTROLLER CONFIGURATION VIA WEBAPP

FOREWORD

For detailed account registration instructions, see the Registration Guide (M0548)

After assigning the SYSTEM CODE to the controller, you must check if the controller is present in the cloud. the connect from your browser: Google Chrome, Microsoft Edge or Mozilla Firefox to the following link: <https://bsmart.piusi.com/>
The WebApp login screen opens:

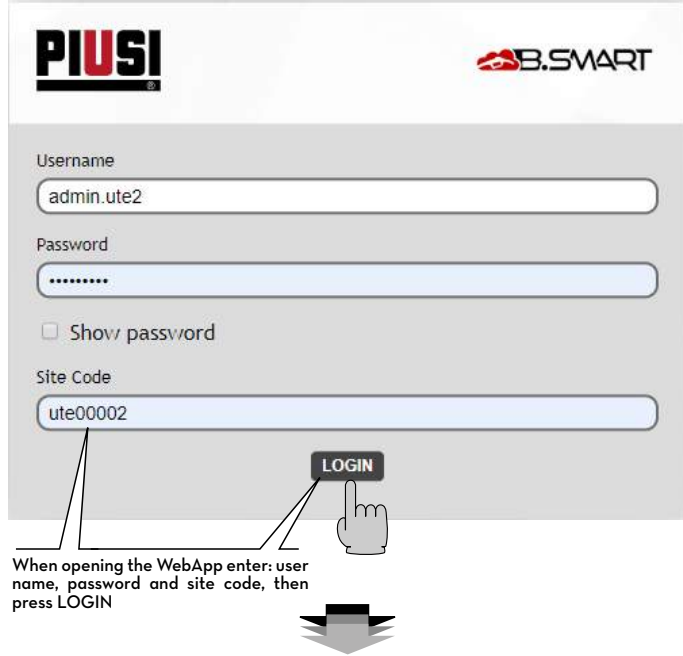

When opening the WebApp enter: user name, password and site code, then press LOGIN





Full details of the WebApp functions (such as managing drivers, registration numbers, dispensing reports and configurations) can be found in the dedicated manual, loaded in the dedicated area of the WebApp.

15 START-UP

FOREWORD

For a correct start-up of CUBE B.SMART, in addition to the activation of apps and webapps, it is necessary to perform some simple operations.

POWER SUPPLY

Once the electrical connections have been made, it is possible to power the CUBE B.SMART by means of the main switch that the installer must arrange on the upstream line.

The system will be turned on when the backlit LCD screen installed on the front panel is activated. Even if you remove the nozzle from its housing, the pump will NOT start, as it is not enabled by the B.SMART system.

PUMP WETTING

CUBE B.SMART is equipped with a self-priming pump that facilitates the first start-up activities. It is therefore not necessary for the suction pipe to be completely filled with diesel for starting up. For rapid priming, particularly in installations with a significant height difference between the pump and the tank, it is nevertheless important that the pump is "wet", i.e. that a minimum quantity of diesel is present inside the impeller chamber. The pump is delivered properly "wet" and ready for use. If, however, the installer believes that the pump is completely dry, for example due to prolonged storage, he must wet it as he deems most appropriate.

15.1 FIRST PRIMING

For priming the pump:

- Pull the nozzle out of its housing
- ACTIVATE THE DELIVERY (VIA APP, WEBAPP OR I-BUTTON KEY)
- Raise the control lever
- The pump will start immediately and continue running indefinitely until the control lever is turned to the OFF position



- Operate the lever of the automatic nozzle, keeping the spout inside a suitable container or the suction tank itself. Initially, air will come out of the nozzle and after a certain time the DIESEL will start to flow out.

IMPORTANT



The first priming of the pump must be carried out by competent personnel who shall be present at all stages. If the air-only delivery phase should take longer than a couple of minutes, STOP the PUMP and check that:

- The pump does not run completely dry, but is at least "wet" with diesel.
- The suction pipe guarantees total absence of air infiltration and is completely immersed.
- The filters are not clogged.
- The suction and/or discharge pipes are not blocked.
- The installation (height difference, diameter and pipe length) complies with the limits described in chapter 14.
- The shut-off valve is closed.

Continue dispensing until the flow is constant and free of air. Set the control lever to the OFF position: The pump stops. Re-position the nozzle in its housing.

16 FLOW METER CALIBRATION

Before you can use the **CUBE B.SMART**, it is advisable that you check the **METERING ACCURACY**.

To do so, proceed as follows:

- Enter a previously enabled USER PIN
- Dispense in a calibrated container
- Compare the quantity of diesel delivered with a calibrated container.

IMPORTANT



For a correct on accuracy it is essential to observe the following indications:

- **Use a precision sample vessel with a graduated scale with capacity indication of not less than 20 litres.**
- **Before checking, be sure to remove all air from the system, dispensing until a full and regular flow is obtained.**
- **Continuously dispense at the maximum flow rate of CUBE B.SMART**
- **Stop the flow by quickly closing the dispensing nozzle.**
- **Reach the graduated area of the sample vessel avoiding prolonged low flow rate deliveries, rather making short dispensings at maximum flow rate.**
- **Compare the indication provided by the container with the indication provided by CUBE B.SMART, after waiting for any foam to disappear.**

If the accuracy is NOT satisfactory, proceed with a CALIBRATION OF THE FLOW METER as indicated in the specific manual.

IMPORTANT



Differences of up to 1/10 litre on 20-litre dispensings are within the guaranteed accuracy of +/- 0.5%

IMPORTANT



For dispensings of 2 litres or less, the manufacturer does not guarantee the same metering accuracy.

17 DAILY USE

All CUBE B.SMART models guarantee restricted access only to authorized users. The SYSTEM recognizes the User's authorization through two alternative systems:

- REGISTRATION OF THE USER IN THE B.SMART APP
- Insertion of an electronic key

IMPORTANT



All AUTHORIZED USERS must be properly trained and be aware of at least what is described in this chapter.

The configurability of the B.SMART system allows the User to ENTER additional optional data (vehicle number plate, mileage, quantity to be dispensed). See DIGITAL APP manual FOR ALL DETAILS. If these options are not set, B.SMART recognizes the authorized USER and immediately enables the pump, allowing the dispensing.

IMPORTANT



Enabling does not result in the immediate start of the pump; the pump is controlled by a switch (located in the nozzle housing) operated by the user.

The pump starts (if previously enabled) as soon as the control lever is in the ON position, while it switches off as soon as the control lever is in the OFF position. No further manual action is necessary to start or stop the pump.

18 DRIVER ACCESS

18.1 FIRST DRIVER ACCESS FROM APP

FOREWORD

To use the APP as a driver, the manager must have created the driver profile via WebAPP, (see WebAPP manual, chapter 1, section 1.1 under ADD NEW DRIVER).

Furthermore, to do this, your smartphone must be connected to the 3/4G or Wi-Fi network, so check the status at the bottom left of the screen:



OFFLINE: APP/smartphone not connected to 3/4G or Wi-Fi

ONLINE: APP/ smartphone connected to 3/4G or Wi-Fi

Afterwards the driver can authenticate himself in the APP:

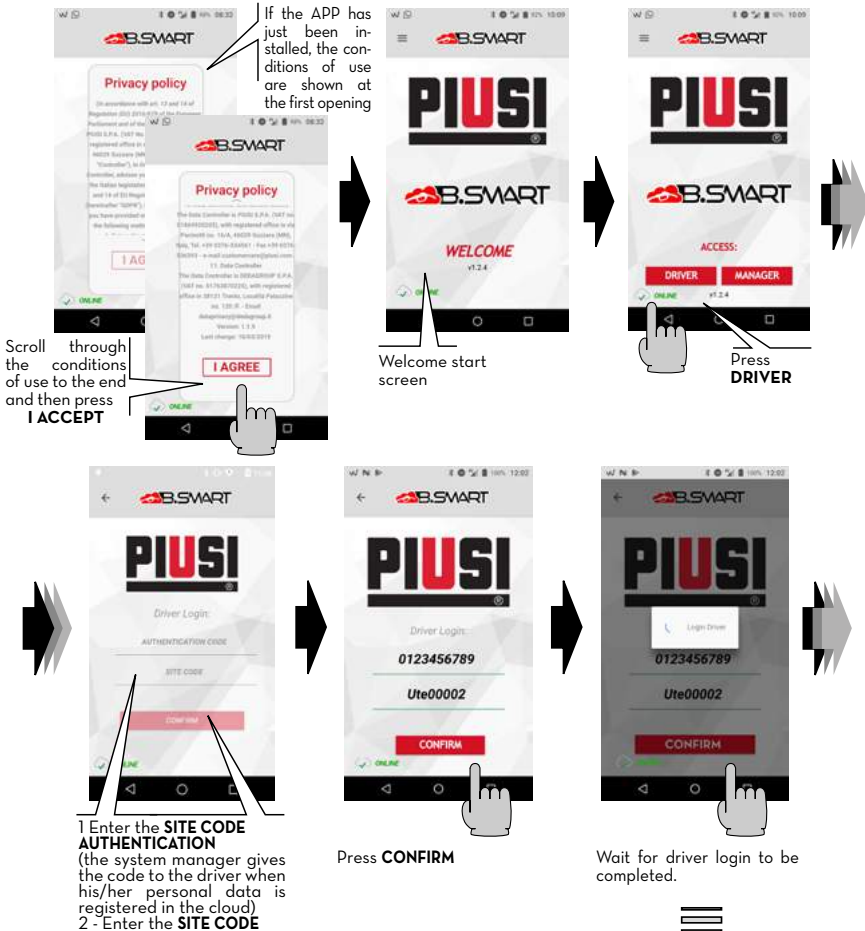

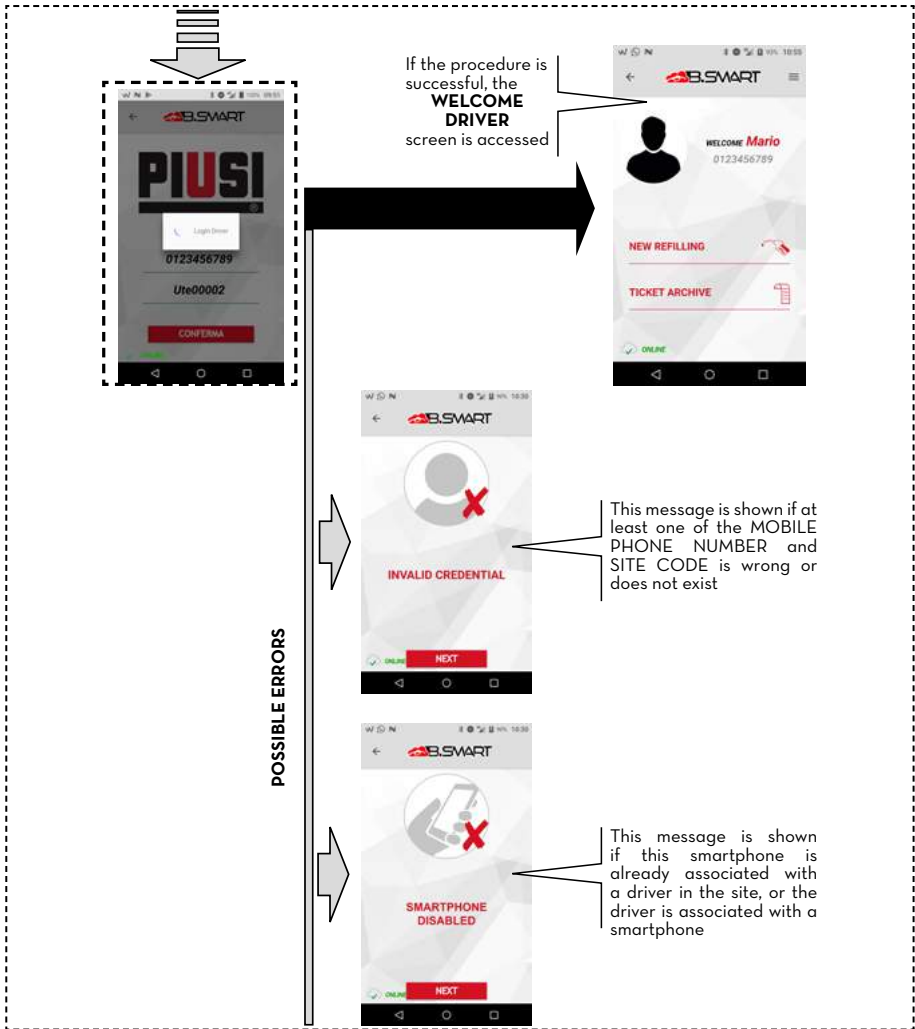

18.2 DRIVER - DISPENSING VIA APP

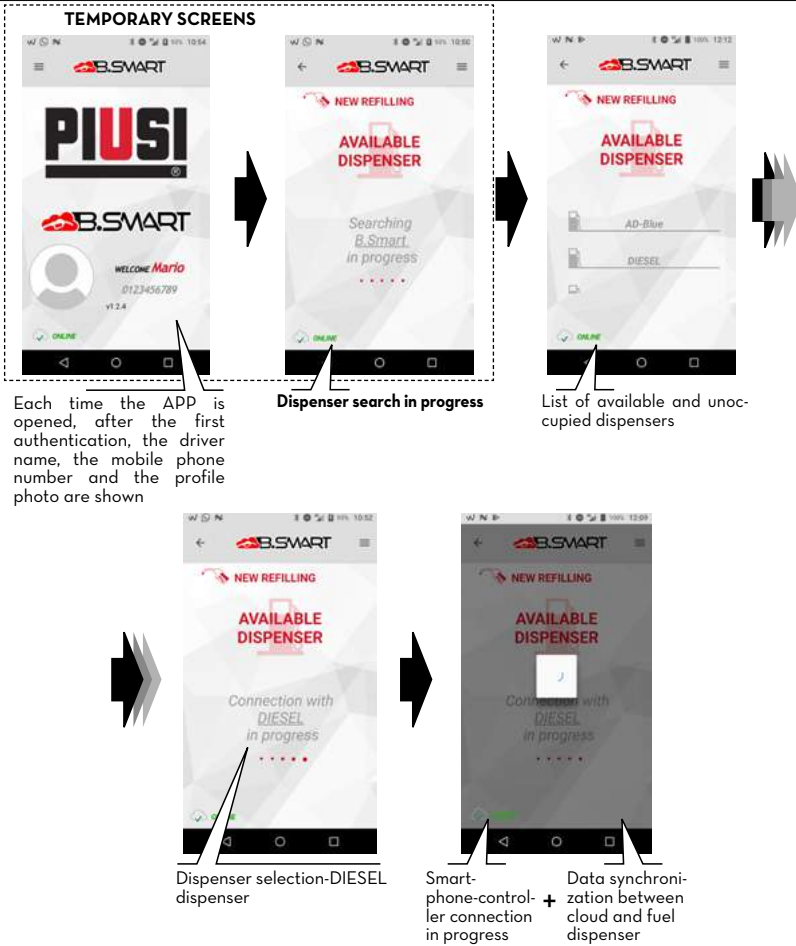

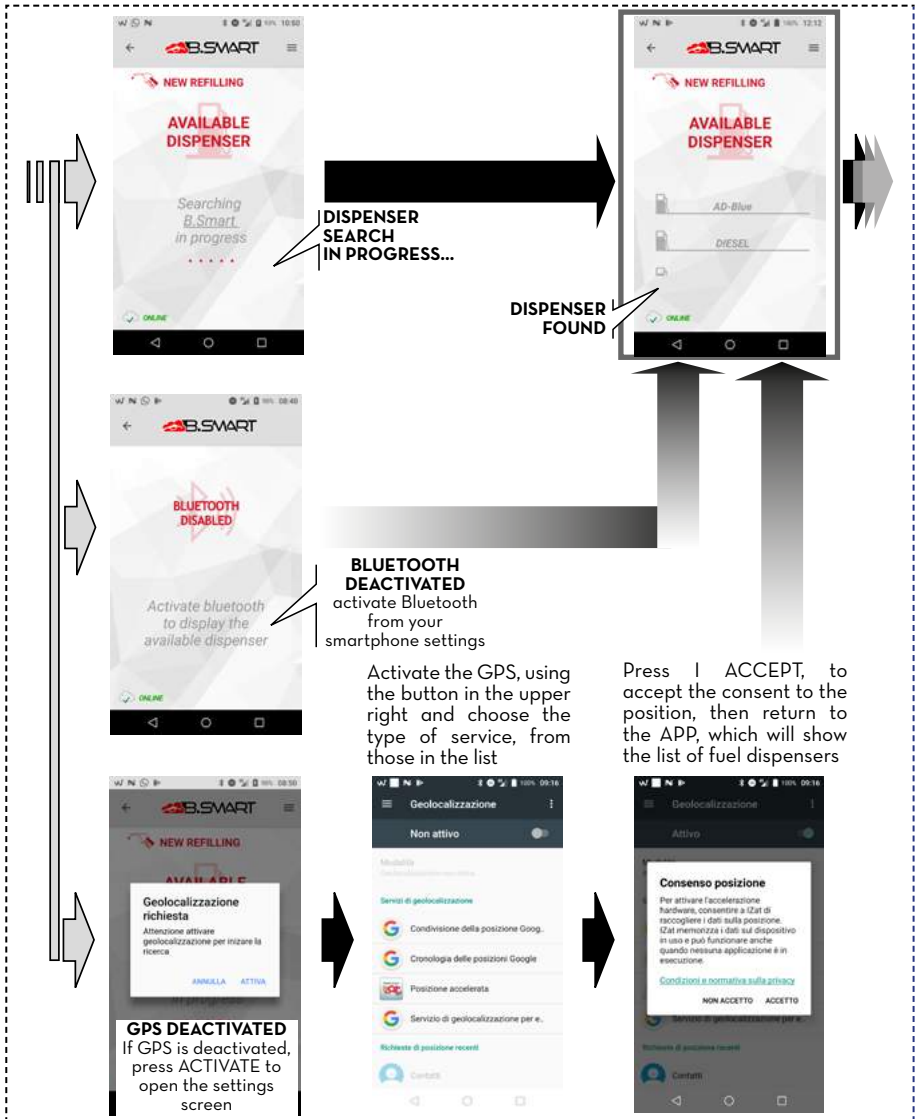

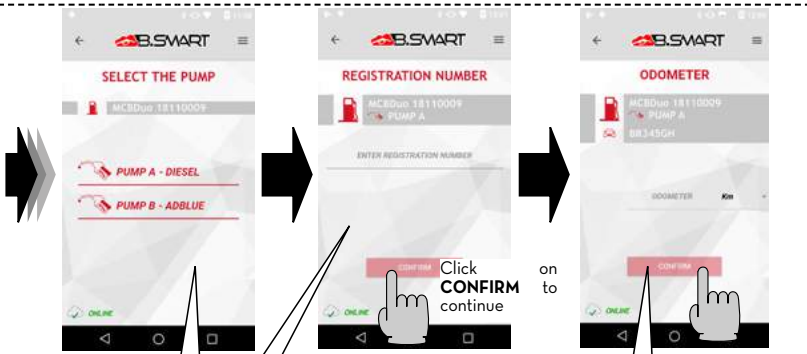

Select the pumping unit to be used for dispensing.

OPTIONAL request, decided by the manager based on how he has configured the webAPP (if he wishes this request to be made of the user or not).

Enter "Registration Number" (this could be the license plate of the vehicle using the pump or another reference code useful to the system manager)

In this example **ab123cd** is entered.

OPTIONAL request Enter odometer, this page appears only if the manager has enabled use of the odometer in the WebApp. In this case **1000** is entered.

Click **CONFIRM** on to continue

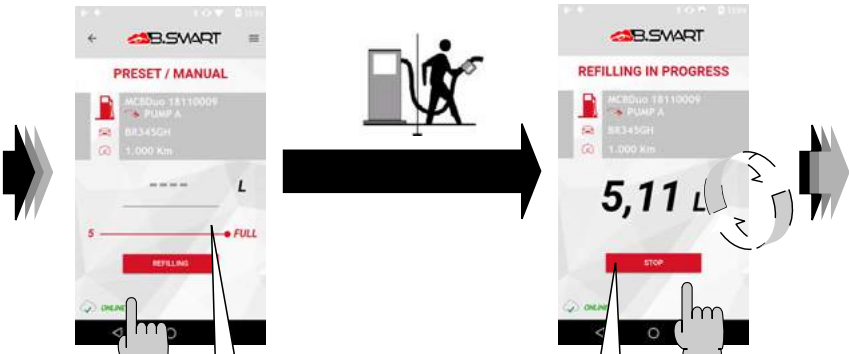

Click **REFUEL** on to continue

Enter the **PRESET** quantity to be delivered. If no value is set the tank will be filled.

Fuel delivery in progress: If a **PRESET** quantity has been entered, this quantity is shown under the meter.

Click on **STOP** to stop dispensing.

This value does not appear if the setting **FULL** has been entered.

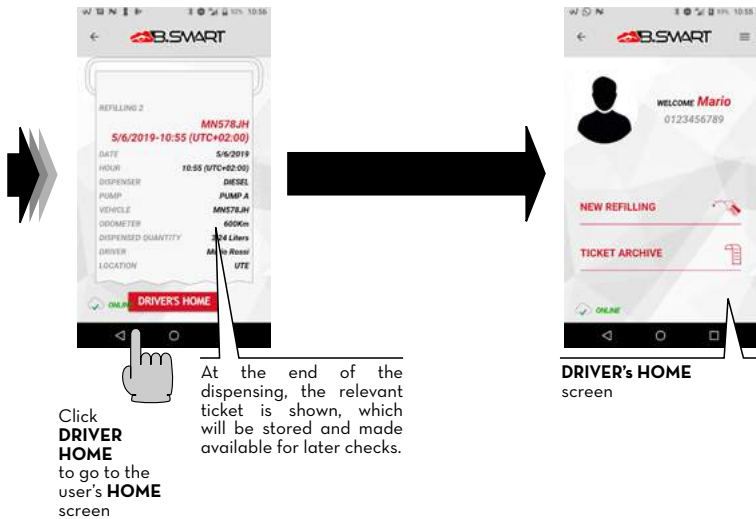

NOTE



The **NEW REFILLING** procedure can be performed either **ONLINE** (smartphone connected to the **3/4G** or **Wi-Fi** network), as in the example described, and **OFFLINE**, therefore from a smartphone not connected to the **3/4G** or **Wi-Fi** network. In the **OFFLINE** conditions, the dispensings will not be immediately uploaded to the cloud, rather as soon as that smartphone has the **APP** open in an area with **3/4G** signal, or as soon as a new smartphone connected to the **3/4G** network or **Wi-Fi** connects to the controller.

18.3 DISPENSING VIA USER KEY (I-BUTTON)

When the manager creates the driver he can add an electronic key (iButton) which is used to perform the access. To do this, just add the last 7 digits of the hexadecimal code associated with the key to the input of the driver's card in WebAPP (see WebApp manual, chapter "ADD NEW DRIVER").



The i-Button serves as a means of authentication to replace the smartphone. For the dispensing, simply place the iButton on the reader in the controller: authentication takes place, then you can start dispensing. Dispensings are uploaded to the cloud as soon as a smartphone with an active data connection connects to the controller.

CAUTION



Dispensing via the iButton key is allowed only when the procedures indicated in paragraphs 14.2, 14.3 and 18.1 have been successfully completed using a smartphone and the WebApp.

NOTE



These procedures are fundamental, as they allow the Manager to configure the system and manage its controllers while at the same time ENABLING THE DRIVER TO DISPENSE VIA A SPECIFIC CONTROLLER.

Dispensing via iButton is recommended only when strictly necessary in those case where it is impossible to dispense via a smartphone. This is because dispensing with iButton does not allow for direct cloud updating, thus compromising the real potential of the system.

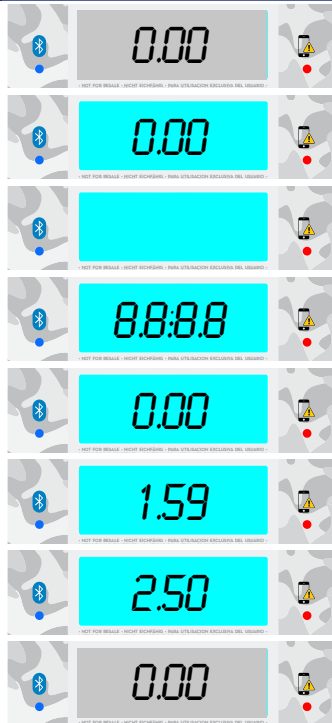

Driver authentication via i-Button

Dispensing start

Dispensing end

19 MAINTENANCE

19.1 ROUTINE MAINTENANCE

Safety information

CUBE B.SMART has been designed to minimize maintenance activities. For maximum efficiency and safety of the station, however, the following routine inspection and maintenance operations must be carried out regularly.

The distribution system was designed and produced to require minimal maintenance.

Before carrying out any kind of maintenance, the distribution system must be disconnected from all sources of electrical and hydraulics supply including the battery.

During maintenance, using the personal protective equipment (PPE) is mandatory.

In any case, bear the following minimum recommendations for efficient system operation in mind.

Staff authorised for maintenance operations IMPORTANT

Maintenance operations must be performed solely by specialist staff. Any tampering may impair the performance and endanger persons and/or property, as well as invalidate the warranty.



Maintenance of electrical parts may only be carried out by qualified electrical or electronic personnel.

Before performing any maintenance, make sure to disconnect the device from the power line to switch it off and isolate it from the power mains.

If the device is sold without cable, periodically check the grounding circuit in accordance with the regulations in force.

OPENING AND CLOSING OF CUBE B.SMART

- Lower the display cover
- Loosen the 2 screws on the right side (indicated with the arrows)
- Open the inspection side of the CUBE B.SMART
- To close again, proceed in the opposite direction.

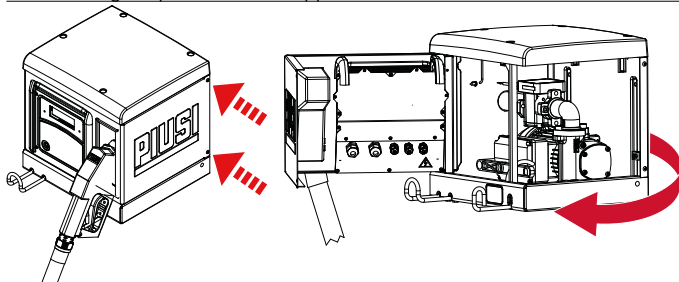

PUMP AND PIPES

Check and keep the pump, the pipes and other internal station components clean. Check that the flanged or threaded connections do not show leaks and that the hoses are intact and not damaged (refer to the manual for pumps and flow meters).

DISPENSING HOSE AND NOZZLE

Keep the dispensing hose and nozzle clean, checking in particular that:

- The hose is intact and not damaged by the transit of vehicles
- Threaded connections are tight and do not show any leaks
- Swivel connections (at the station exit and on the nozzle) rotate freely and do not show any leaks
- The hole in the automatic stop probe at the end of the nozzle hose (spout) is always clean.

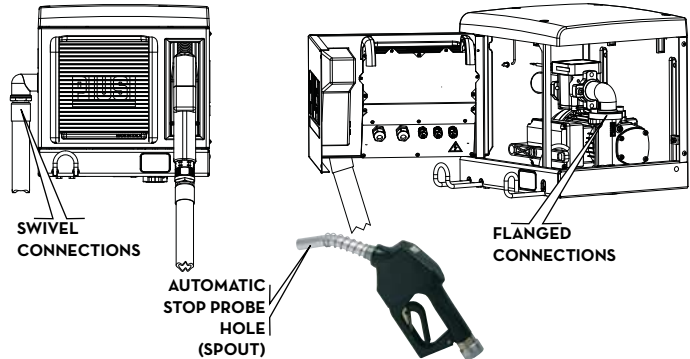

FILTERS

CUBE B.SMART is equipped with some filters, having different functions. Checking and cleaning (or replacing) each of them is of utmost importance to ensure:

- Protection of the various station components (pulsar, pump, nozzle)
- Maintaining station performance over time (maximum flow rate)
- The protection of the engines in which the diesel dispensed is used

IMPORTANT



Dirty or partially clogged filters can increase pressure drop so that the maximum flow rate dispensed by the pump is significantly reduced. Dirty or clogged filters at the pump suction also generate a significant vacuum increase in the suction which can also cause a significant increase in the noise level of the pump.

PUMP FILTER (ONLY FOR AC VERSIONS)

It is installed in the pump body as standard equipment of the PANTHER pump. To check and clean it:

- 1 - Loosen the two screws of the filter cover and remove it from the body.
- 2 - Pull the mesh filter out, using pliers.
- 3 - If it is necessary to clean it, wash it and blow it.
- 4 - Carefully replace the filter in the housing of the pump body, taking care that it does not protrude from the housing of the cover.
- 5 - Check and clean the flat seal, re-position the cover and tighten the screws.

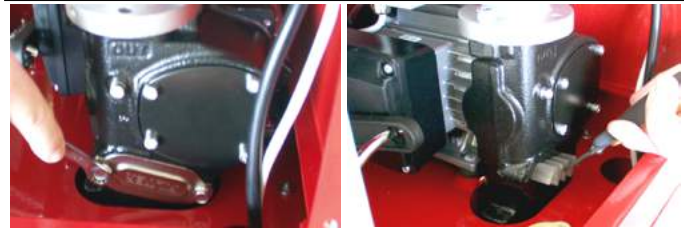

PULSER FILTER

The pulser filter provides additional protection against the risk of foreign bodies entering the oval gear pulser. As this filter is installed downstream the pump suction filter, regular checking and cleaning is not required. If the need arises and/or in case of extraordinary maintenance, it can be cleaned as described in the PULSER MANUAL, after disassembling the roof of CUBE B.SMART, using the screws located above it (see exploded drawing).



PULSER

The pulser flow meter is a measuring instrument characterized by high precision, guaranteed by the accuracy of machining and assembly. No routine maintenance is normally required. Calibration, normally carried out during the installation of the station, can be carried out again if precision checks, to be repeated every 3/6 months, recommend so. Calibration is performed electronically via the management system, and does not require any intervention on the pulser. For any information, refer to the K600 flow meter manual.

19.2 EXTRAORDINARY MAINTENANCE

IMPORTANT



Maintenance of electrical parts may only be carried out by qualified electrical or electronic personnel.

Before performing any maintenance, make sure to disconnect the device from the power line to switch it off and isolate it from the power mains.

If the device is sold without cable, periodically check the grounding circuit in accordance with the regulations in force.

1 - Firmware update via smartphone, see dedicated section in the APP manual

2 - Fuse control: to access the fuses it is necessary to open the unit and access the parts that are live during normal use, to operate safely disconnect the general power supply from the unit



19.3 CHECK AND REPLACEMENT OF FUSES

For checking and replacing fuses on electronic boards:

- 1 Cut the unit off the power supply;
- 2 Open the CUBE B.SMART door by loosening the 2 side screws to access the controller

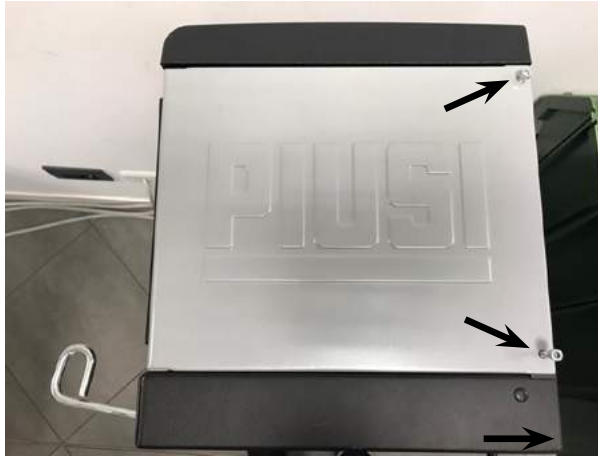

- 3 Loosen the screws of the metal rear cover to access the compartment of the electronic boards

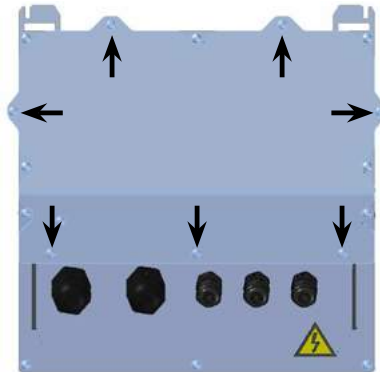

- 4 Check the condition of the 3 fuses and replace them if necessary

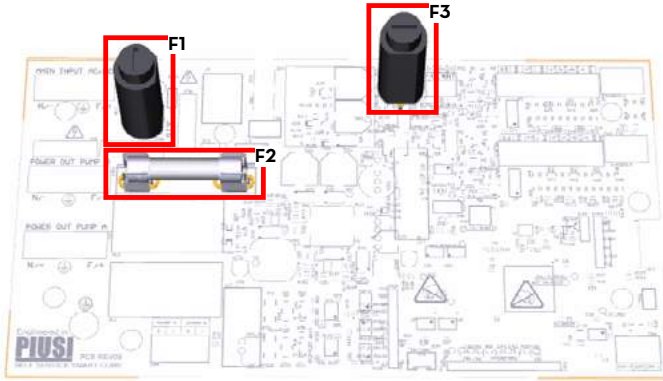

- F1 • Power supply fuse at AC power supply input 800 mA T (delayed)
- F2 • Motor fuse 20 A T (delayed)
- F3 • Power supply fuse at AC/DC converter output 800 mA T (delayed)

5 Tighten the screws of the metal rear cover to close the compartment of the electronic boards and power

20 TROUBLESHOOTING

20.1 MECHANICAL AND HYDRAULIC PROBLEMS

PROBLEM	POSSIBLE CAUSES	POSSIBLE SOLUTIONS
THE MOTOR DOESN'T TURN	Lack of power	Set the ON/OFF switch on the pump to the ON position. Reset the external differential switch Check electrical connections
	Fuses blown	Replace fuses in the electric panel
	Motor problems	If the rotor is blocked, disassemble and check for damage or obstruction and reassemble. Contact the customer service.
THE MOTOR DOES NOT START AGAIN WITH THE NOZZLE CLOSED	Supply voltage too low	Check that the supply voltage is not 5% lower than the normal V.
FLOW RATE LOW OR ZERO	Excessive suction vacuum	Lower CUBE B.SMART in relation to the level of the tank or increase the section of the pipes.
	High pressure drops in the circuit	Use shorter or larger diameter pipes
	Suction pipe resting on the bottom of the tank	Raise the suction pipe
	Low suction tank level	Refill the tank.
	Air entering the suction pipe or the pump	Check the tightness of the connections and the level of the diesel in the tank
	Low motor rotation speed	Check the voltage to the motor: adjust the voltage or/and use cables with a greater section
	Check valve blocked	Clean or replace
	Tank filter clogged	Clean the filter
	Pump filter clogged	Clean the filter
	Fluid loss	Check the tightness of the connections and the condition of the rubber hoses
INSUFFICIENT FLOW METER ACCURACY	Flow meter chamber obstructed	Clean the flow meter chamber
	Presence of air in suction	Check the tightness of the connections
THE NOZZLE TRIPS TOO OFTEN	Calibration insufficient	Calibrate the flow meter
	Automatic stop probe hole blocked	Clean the automatic stop probe hole from dirt and/or obstructions



20.2 ELECTRICAL/ELECTRONIC CONNECTIONS

PROBLEM	POSSIBLE CAUSES	POSSIBLE SOLUTIONS
CUBE B.SMART does not switch on	Lack of power DUE TO:	
	<ul style="list-style-type: none"> • Incorrect connections • Upstream circuit breaker in OFF position • Fuse on power supply interrupted 	Check connections Set circuit breaker to ON position Check fuse
A driver with an electronic key is not recognized	The electronic key has not been associated by the MANAGER	The system MANAGER associates the key to the driver
	The electronic key has been damaged and is no longer recognized by the system	Change the electronic key, the system MANAGER will also have to delete the code of the old key and associate the new key to the driver via WebAPP
The motor does not start	It has not been connected correctly to the terminals provided	Check connections, or (if present) check that the position of the motor switch is in the ON position
Does not count during dispensing	The Pulsar that emits the counting signals is not correctly connected	Check connections
	The Pulsar that emits the counting signals is NOT compatible with the electronics	The electronics are designed to receive a "clean contact" or "Open Collector" signal as input. If the input signal is an incompatible voltage signal, in addition to the malfunction the electronic board is likely to be damaged
	Pulsar board damaged	Replace Pulsar board
The counting is not accurate	The system is NOT calibrated	Calibrate the system according to the procedure
The counting is not accurate even after calibration or is only accurate at low flow rates	The signal coming from the Pulsar is out of the ranges acceptable by the electronics	The signal received by the pulser must be with max. frequency 300 Hz and Duty Cycle between 10% and 90%. Beyond these ranges, the system does not process the received data correctly. The system must fall within the correct ranges by interposing other electronic interface devices (contact the Technical Assistance for these particular options)

20.3 PROBLEMS WITH THE SMARTPHONE APP

PROBLEM	POSSIBLE CAUSES	POSSIBLE SOLUTIONS
APP signals that the driver is not enabled	The manager didn't enable the driver to the dispenser	The MANAGER enables the driver to the dispenser via WebAPP in the section dedicated to drivers
Dispensing from smartphone is not present in the cloud	Dispensing was made with the smartphone with data connection disabled or in an area with poor 2G/3G/4G coverage	Dispensing will be in the cloud as soon as the APP is opened in an area with 2G/3G/4G coverage. In the meantime it will be stored on the memory of the smartphone and also in the memory of the dispenser
APP does not see the controller, but Bluetooth is active	Bluetooth module on the smartphone is not compatible with the Bluetooth module of the dispenser	The Bluetooth module of the dispenser is compatible with all smartphones that feature the Bluetooth version 4.0 or later (smartphones from 2011 onwards)
	Dispenser occupied by another driver	The dispenser will be visible from the smartphone only when the driver who is using it has finished operations

21 FAQ

- | | |
|--|---|
| <p>1 If a driver changes smartphone, is it necessary to create a new account for that driver or can he continue to use what he already had?</p> <p>IMPORTANT</p>  | <p>If the driver changes smartphone, he must notify the site manager, who will delete / reset the smartphone - driver association in the WebApp (procedure described in the manual of the WebApp, chapter "DRIVER DETAIL").
The driver can then log in from the APP installed on the new smartphone.</p> <p>After the manager has deleted the smartphone - driver association, the driver is obliged to access with a smartphone other than the previous one, because access with his credentials is prevented on the old device. To be able to access with the old smartphone, you must first access with a new smartphone, then be reset as user and finally enter with the initial smartphone</p> |
| <p>2 What if a driver loses his smartphone?</p> | <p>If the driver loses his smartphone, it is necessary to notify the site manager, who will immediately remove the smartphone - driver association. The procedure to be followed is the same as that indicated in question 1.</p> |
| <p>3 What if the APP reports that the smartphone is not recognized?</p> |  <p>Generally it is an error shown when the driver has changed smartphone but has kept the same phone number and the site manager has not reset the user.</p> <p>In this case the driver must contact the manager and inform him of the error shown by the APP. The manager will remove the smartphone - driver association to allow the driver to login from the new smartphone. The procedure to be followed by the manager is the same as that indicated in question 1 (see also the WebApp manual, chapter "DRIVER DETAIL")</p> |
| <p>4 When are dispensings made via iButton or smartphones without an internet connection uploaded to the cloud?</p> | <p>There are 4 cases in which the dispensings are uploaded to the cloud:</p> <ul style="list-style-type: none"> • Each time the APP is opened, if the data connection is active • APP open in the background and data connection active • Data synchronization by the manager by pressing the SYNCHRONIZATION key • Every time a driver connects to the controller and the internet connection of the smartphone is active <p>As you can see from the list, the dispensings can be uploaded to the cloud even if your smartphone is not connected to the controller.</p> |

5 What if I can't dispense via authentication with iButton?

There are a few possible cases:

- Dispensing memory full
- Tank empty
- iButton not associated with any driver

In detail:

Dispensing memory full and tank empty



The red LED to the right of the controller display is on. This may indicate problems in the memory (dispensing memory full) or tank empty.

To empty the dispensing memory, synchronize with the cloud. If the problem is not solved, reset the controller

iButton not associated with any driver



When the iButton is placed on the reader the display does not light up

6 What if a driver changes his phone number and keeps the same smartphone?

If a driver changes number it is necessary to inform the manager, who will change it from the driver's card in the WebApp (see also the manual of the WebApp, chapter "DRIVER DETAIL").



In the APP, the number is automatically updated the first time you connect to the cloud. From now on the mobile phone number will be the one to be used to access the APP. In addition, in the case of mobile number portability between different mobile operators, it is likely that for a few days the mobile number will be the temporary one, and then the mobile number will be the same again as soon as portability is complete. In this case, during the transition period, there is no need to notify the site manager of the temporary number, you can continue to use your original telephone number.

22 SCRAPPING AND DISPOSAL

22

Foreword

If the system is scrapped, its components must be consigned to companies specialised in the disposal and recycling of industrial waste and, in particular:

Disposal of the packaging

The packaging is made of biodegradable cardboard that can be handed over to companies for the normal recycling of cellulose.

Disposal of metal parts

The metal parts, both painted and stainless steel, can normally be recycled by companies specialised in the metal scrapping sector.

Disposal of electrical and electronic components

These must of necessity be disposed of by companies specialised in the disposal of electronic components, in compliance with the indications of the directive 2012/19/EU (see directive text below).

Environmental information for customer resident in the European Union



European Directive 2012/19/EU requires equipment marked with this symbol on the product and/or packaging not to be disposed of together with mixed municipal waste. The symbol indicates that this product must not be disposed of together with normal domestic waste. It is the responsibility of the owner to dispose of both these products and other electrical and electronic equipment through the specific collection facilities indicated by the government or local public authorities.

The disposal of Waste Electrical and Electronic Equipment (WEEE) as domestic waste is strictly prohibited. This type of waste must be disposed of separately.

Any dangerous substances that may be present in the electrical and electronic equipment and/or incorrect use of such equipment may potentially have serious consequences for the environment and human health.

In the case of unlawful disposal of such waste, the sanctions envisaged by the regulations in force may be applied.

Disposal of further parts

Further product parts, such as hoses, rubber seals, plastic parts and wiring should be handled by companies specialising in industrial waste disposal.

23 EXPLODED VIEWS

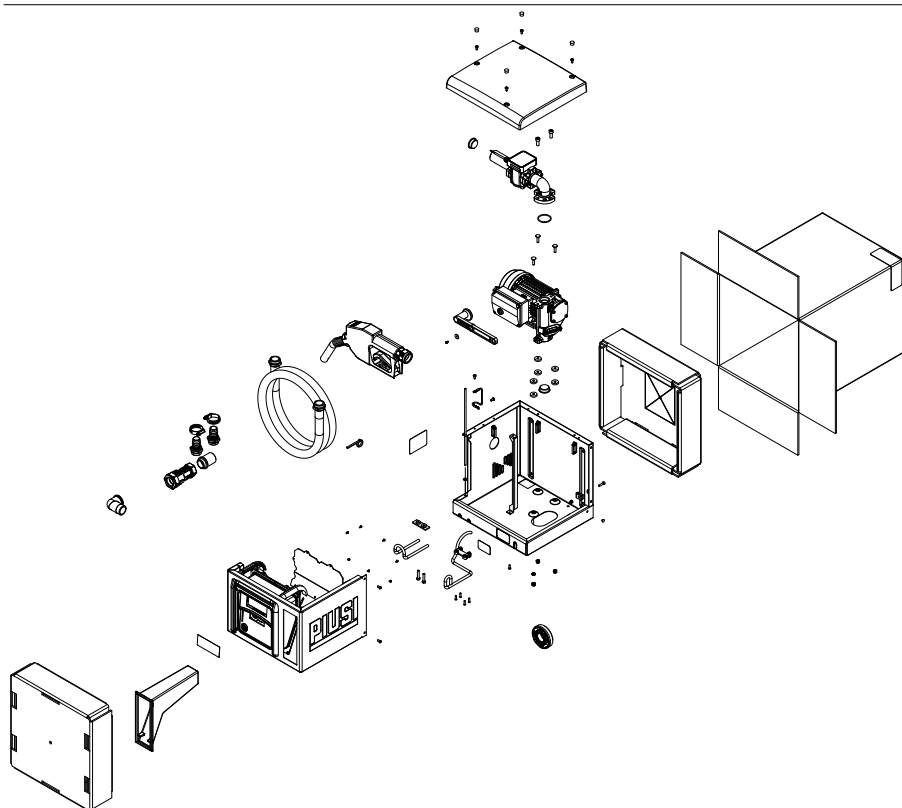



© PIUSI S.p.A.

EN. This document has been written with the utmost attention concerning the accuracy of the data contained in it. PIUSI S.p.A. accepts no responsibility for any errors or omissions however.



IT Scarica il manuale nella tua lingua!
EN Download the manual in your language!
CS Stáhnout příručku ve vašem jazyce!
DA Download manualen på dit sprog!
DE Laden Sie das Handbuch in Ihrer Sprache herunter!
ES ¡Descarga el manual en tu idioma!
FI Lataa käsikirja omalla kielelläsi!
FR Téléchargez le manuel dans votre langue!
NL Download de handleiding in uw taal!
PL Pobierz instrukcję w swoim języku!
PT Baixe o manual em seu idioma!
RU Загрузите руководство на вашем языке



[https://www.piusi.com/
support/search-manuals](https://www.piusi.com/support/search-manuals)

piusi.com
PIUSI SpA • Suzzara MN Italy

BULLETIN MO546 EN_03

01.2024